

**100 AMP REGULATOR
(SOLID STATE)**

NSN 2920-00-900-7993

CHECKOUT AND REPAIR PROCEDURES

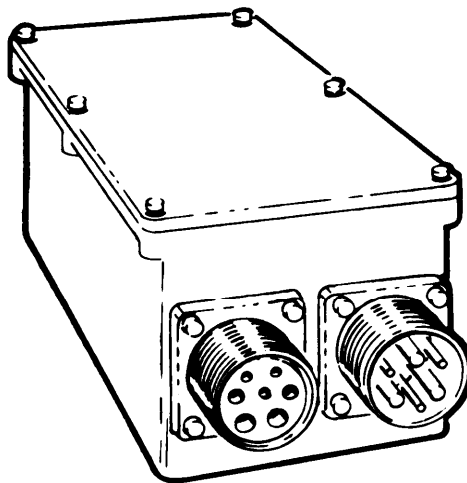

HEADQUARTERS, DEPARTMENT OF THE ARMY

10 NOVEMBER 1981

**100 AMP REGULATOR
 (SOLID STATE)
 (NSN 2920-00-900-7993)
 CHECKOUT AND REPAIR PROCEDURES**

REPORTING OF ERRORS

Reporting Errors and Recommending Improvements. You can help improve this bulletin. If you find a mistake or if you know of away to improve the procedures, please let us know. Mail your letter, DA Form 2028 (Recommended Changes to Publications and Blank Forms), or DA Form 2028-2 located in the back of this bulletin to: US Army Tank-Automotive Command, ATTN: DRSTA-MB, Warren, MI 48090. A reply will be furnished direct to you.

| | <i>Paragraph</i> | <i>Page</i> |
|---|------------------|-------------|
| CHAPTER 1. INTRODUCTION | | |
| Section I. General _____ | 1-1 | 1-1 |
| II. Fundamentals of Solid State Component Checkout and Repair _____ | 1-6 | 1-2 |
| CHAPTER 2. VAP-AIR MODELS | | |
| Section I. Introduction _____ | 2-1 | 2-1 |
| II. Vap-Air Model 26440001-01 _____ | 2-4 | 2-3 |
| | | 2-5 |
| IV. Vap-Air Model 26440001-04 _____ | 2-8 | 2-13 |
| V. Vap-Air Model 26440001-05 _____ | 2-10 | 2-22 |
| CHAPTER 3. LEECE-NEVILLE MODELS | | |
| Section I. Introduction _____ | 3-1 | 3-1 |
| II. Leece-Neville Model R0015027RA _____ | 3-4 | 3-3 |
| III. Leece-Neville Model R0015027RB _____ | 3-6 | 3-7 |
| IV. Leece-Neville Model R0015027RC _____ | 3-8 | 3-9 |
| V. Leece-Neville Model R0015027RD _____ | 3-10 | 3-15 |
| CHAPTER 4. LELAND AIRBORNE MODEL | | |
| Introduction _____ | 4-1 | 4-1 |
| 5. 100 AMP REGULATOR CHECKER | | |
| Purpose _____ | 5-1 | 5-1 |
| APPENDIX A. CONSOLIDATED NATIONAL STOCK NUMBERS (NSN) AND FEDERAL SUPPLY CODES FOR MANUFACTURERS (FSCM) _____ | | A-1 |

LIST OF ILLUSTRATIONS

| <i>Figure</i> | <i>Title</i> | <i>Page</i> |
|---------------|--|-------------|
| 1-1 | 100 AMP regulator _____ | 1-2 |
| 2-1 | NPN transistor (Vap-Air) _____ | 2-2 |
| 2-2 | Transistor resistance checks (Vap-Air) _____ | 2-2 |
| 2-3 | Vap-Air mode126440001-01 _____ | 2-4 |
| 2-4 | Diode mounting—model 01 _____ | 2-5 |
| 2-5 | Vap-Air model 26440001-03 _____ | 2-6 |
| 2-6 | End view—mode103 _____ | 2-7 |

| <i>Figure</i> | <i>Title</i> | <i>Page</i> |
|---------------|---|-------------|
| 2-7 | Circuit board—model 03_ _ _ _ _ | 2-8 |
| 2-8 | Test points—model 03_ _ _ _ _ | 2-9 |
| 2-9 | Schematic diagram—model 03_ _ _ _ _ | 2-10 |
| 2-10 | Vap-Air model 26440001-04_ _ _ _ _ | 2-14 |
| 2-11 | End view—model 04_ _ _ _ _ | 2-15 |
| 2-12 | Diode mounting—model 04_ _ _ _ _ | 2-17 |
| 2-13 | Relay location—model 04_ _ _ _ _ | 2-18 |
| 2-14 | Circuit board and transistor heat sink-model 04_ _ _ _ _ | 2-19 |
| 2-15 | Test points—model 04_ _ _ _ _ | 2-20 |
| 2-16 | Schematic diagram—model 04_ _ _ _ _ | 2-21 |
| 2-17 | Vap-Air model 26440001-05_ _ _ _ _ | 2-23 |
| 2-18 | End view—model 05_ _ _ _ _ | 2-24 |
| 2-19 | Diode mounting—model 05_ _ _ _ _ | 2-25 |
| 2-20 | Relay location—model 05_ _ _ _ _ | 2-26 |
| 2-21 | Circuit board and transistor heat sink—model 05_ _ _ _ _ | 2-27 |
| 2-22 | Test Points-model 05_ _ _ _ _ | 2-28 |
| 2-23 | Schematic diagram—model 05_ _ _ _ _ | 2-29 |
| 3-1 | NPN transistor (Leece-Neville)_ _ _ _ _ | 3-2 |
| 3-2 | Transistor resistance checks (Leece-Neville)_ _ _ _ _ | 3-2 |
| 3-3 | Top view (Leece-Neville)—model 5027RA_ _ _ _ _ | 3-3 |
| 3-4 | Circuit board—model 5027RA_ _ _ _ _ | 3-4 |
| 3-5 | Schematic diagram—model 5027RA_ _ _ _ _ | 3-5 |
| 3-6 | Leece-Neville model 5027RB exploded view_ _ _ _ _ | 3-8 |
| 3-7 | Openview—mode15027RB_ _ _ _ _ | 3-9 |
| 3-8 | Leece-Neville model 5027RC exploded view_ _ _ _ _ | 3-10 |
| 3-9 | Openview—mode15027RC_ _ _ _ _ | 3-11 |
| 3-10 | Circuit board—mode15027RC_ _ _ _ _ | 3-12 |
| 3-11 | Schematic diagram—model 5027RC_ _ _ _ _ | 3-13 |
| 3-12 | Leece-Neville mode15027RD_ _ _ _ _ | 3-16 |
| 3-13 | Circuit board removed—model 5027RD_ _ _ _ _ | 3-18 |
| 3-14 | Test points-model 5027RD_ _ _ _ _ | 3-19 |
| 3-15 | Schematic diagram—model15027RD_ _ _ _ _ | 3-20 |
| 4-1 | NPN transistor (Leland Airborne Model)_ _ _ _ _ | 4-2 |
| 4-2 | Transistor resistance checks (Leland Airborne Model)_ _ _ _ _ | 4-2 |
| 4-3 | Schematic diagram, circuit board, and bracket assy (Leland Airborne model)_ _ _ _ _ | 4-3 |
| 5-1 | 100 AMP solid state regulator checker_ _ _ _ _ | 5-2 |

LIST OF TABLES

| <i>Table</i> | <i>Title</i> | <i>Page</i> |
|--------------|---|-------------|
| 2-1 | Replacement Parts List-Model 01_ _ _ _ _ | 2-3 |
| 2-2 | Resistance Checks (Power-off)-Model 03_ _ _ _ _ | 2-11 |
| 2-3 | Voltage Checks (Power on)—Mode103_ _ _ _ _ | 2-12 |
| 2-4 | Substitutes for Diode D1—Model 03_ _ _ _ _ | 2-18 |
| 2-5 | Resistance Checks (Power otO—Mode104_ _ _ _ _ | 2-15 |
| 2-6 | Voltage Checks (Power on)—Model 04_ _ _ _ _ | 2-16 |
| 2-7 | Substitutes for transistor Q5-Model 04_ _ _ _ _ | 2-18 |
| 2-8 | Resistance Checks(Power off)—Model 05_ _ _ _ _ | 2-30 |
| 2-9 | VoltageChecks (Power on)—Model 05_ _ _ _ _ | 3-30 |
| 2-10 | Substitutes for transistor Q5—Model 05_ _ _ _ _ | 2-31 |
| 3-1 | Resistance Checks (Power off)-Mode15027RA_ _ _ _ _ | 3-6 |
| 3-2 | Voltage Checks (Power on)— Mode15027RA_ _ _ _ _ | 3-6 |
| 3-3 | Resistance Checks (Power off)—Mode15027RC_ _ _ _ _ | 3-14 |
| 3-4 | Voltage Checks (Power on)— Mode15027RC_ _ _ _ _ | 3-14 |
| 3-5 | Resistance Checks (Power off)—Mode15027RD_ _ _ _ _ | 3-17 |
| 3-6 | Substitutes for Diode Z1-Model 5027RD_ _ _ _ _ | 3-17 |
| 4-1 | Replacement Parts List-Leland Airborne Model_ _ _ _ _ | 4-4 |

CHAPTER 1 INTRODUCTION

Section I. GENERAL

1-1. Scope. These procedures are applicable to Direct Support and General Support levels. The instructions are limited to the model described, but may also aid in repairing other 100 AMP regulator (Solid State) models which may be in use. Repair beyond that covered is permissible if time and skills are available.

1-2. Purpose. This bulletin describes the checkout and repair procedures for the 100 AMP regulator (Solid State), NSN 2920-00-900-7993.

1-3. General. *a.* The 100 AMP (Solid State) regulator, NSN 2920-00-900-7993, procured under a military standard performance-type specification. As such, the design and detail drawings are proprietary to each of the manufacturers and are not available. At present, there are three suppliers of the regulators:

(1) *Leece-Neville.*

Code Ident 35510 (FSCM)
Sheller-Glove Corp.
Leece-Neville Cleveland Div.
1374 E. 51 St.
Cleveland, OH 44103
Telephone AC 216 431-0740

(2) *DC Electronics.*

Successors in 1978 to Vap-Air
Code Ident 34904 (FSCM)
DC Electronics Inc.
544 N. Highland Ave.
Aurora, IL 60506
Telephone AC 312844-5170

(3) *Leland Electrosystems Inc.*

Code Ident 07639 (FSCM)
Leland Electrosystems Inc.
740 E. National Road
P.O. Box 128
Vandalia, OH 45377
Telephone AC 513898-5881

b. The 100 AMP regulator was originally designated as non-repairable. However, since fielding, the regulator has consistently appeared as a back order item. This bulletin is provided as an interim

solution to this problem, until maintenance and provisioning studies are finalized, at which time pertinent information may be incorporated in TM 9-2920-225-34 and TM 9-2920-225-34P. The 100 AMP regulator is illustrated in figure 1-1.

c. This bulletin contains instructions for the repair of nine different models which are described in the chapters listed below:

| | |
|-----------|-----------------------------|
| Chapter 2 | Vap-Air (four models) |
| Chapter 3 | Leece-Neville (four models) |
| Chapter 4 | Leland Airborne (one model) |

For simplicity, the regulator model numbers are abbreviated with a portion of the last digits e.g., Vap-Air model 26440002-05 is abbreviated as model 05, Leece-Neville model R0015027RA is abbreviated as model 5027RA.

d. A 100 AMP regulator checker is described in chapter 5. In addition, TB 9-2300-409-30, (Generator System Tester (Go/No-Go), provides fabrication instructions for a regulator test stand.

e. Replacement parts which are not identical with the original parts may cause a change in performance of the regulator. The repair facility should remain aware of this possible performance change and use substitute parts with reasonable caution. Replacement parts should be obtained with the following priorities:

(1) Where parts are available in the supply system, the stock number is provided.

(2) Where no stock number is available, the part should be either obtained from a non-repairable regulator (cannibalization) or ordered from the manufacturer.

(3) Appendix A lists all National Stock Numbers (NSNS) in ascending National Item Identification Number (NIIN) sequence for quick referral to the Federal Supply Code for Manufacturer (FSCM). Addresses for FSCMS are listed in SB 708-41/42.

(4) When all else fails, try a substitute part and monitor the performance of the repaired regulator.

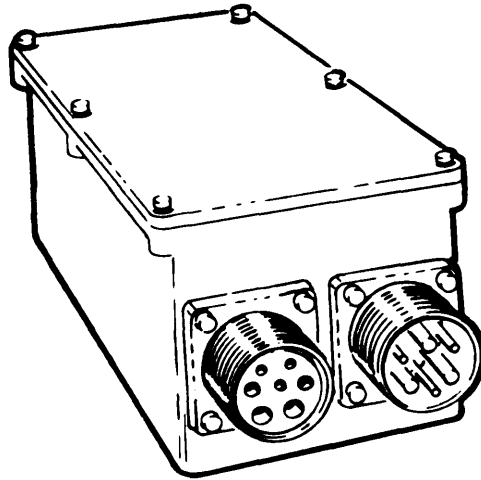

TA 178482

Figure 1-1. 100 AMP regulator.

1-4. Removal and Installation. The regulator must be removed from the vehicle for testing and repair. The procedures given in this bulletin are for bench testing and repair only. Refer to the appropriate vehicle manual for removal and installation procedures for your particular vehicle.

1-5. Major Items Affected. Because of the numerous vehicles affected, a listing of the vehicles will not be supplied. Check the regulator's NSN (2920-00-900-7993) or part number (10947439) in section IV of your vehicle's repair parts manual for applicability.

Section II. FUNDAMENTALS OF SOLID STATE COMPONENT CHECKOUT AND REPAIR

1-6. Introduction. *a.* Checkout and repair of solid state voltage regulators involves techniques different from those employed with mechanical voltage regulators.

b. Before attempting checkout and repair of solid state voltage regulators, follow the instructions of paragraphs 1-7 and 1-8,

1-7. Meters. *a.* The type of meter used to check-out solid state components is critical and should be limited to quality meters such as the TS-352 or the Simpson 260 multimeters, or their equivalent. When using an ohmmeter with unknown technical specifications or characteristics, the following checks can be made to determine if the ohmmeter scales will cause damage to low power transistors.

(1) Check the voltage across the ohmmeter leads as the ranges are switched. No scale should be used if the voltage exceeds 3 volts.

(2) If the instrument is a combination volt-ohmmeter, the positive voltmeter lead may not be the positive ohmmeter lead. The polarity of the ohmmeter leads must be known. Polarity can be determined by connecting the ohmmeter to a voltmeter. If the voltmeter moves up scale the ohmmeter has the same polarity as the voltmeter.

If the voltmeter attempts to move down scale the ohmmeter leads have opposite polarity, e.g., TS-352 multimeter. If necessary mark the ohmmeter leads positive and negative for reference.

b. The ohmmeter readings obtained when checking semiconductor devices depends on the internal makeup of the meter, scale used, type of transistor and its temperature. Therefore, exact resistance readings are seldom given. Readings are usually referred to as low resistance, which is less than 20 ohms; and high resistance which is more than 200 ohms. Occasional failures may occur which can be detected by these tests. If readings obtained are doubtful or operation of the regulator is not proper, replace the transistors.

1-8. DOs AND DON'Ts For Circuit Repair.

a. DO—When replacing solid state circuit boards, clip the connecting wires, leaving a small portion of wire with insulation to act as a reference for connecting points on the replacement board.

b. DON'T—Attempt to interchange circuit boards between regulator models.

c. DO—Use high quality resin core solder of 60-40 tin lead composition.

d. DO—Use a 60W AC or DC soldering iron. Solid state components are easily damaged by excessive heat.

e. DON'T—Allow wires to become pinched between covers, heat sinks, circuit boards, etc.

f. DON'T—Use a screwdriver to pry up transistors during removal. The mica washer between the transistor and the circuit board or heat sink is thin and can be easily damaged.

g. DON'T—Drop transistors since they are easily damaged. If a transistor is dropped it should be checked before being installed in the circuit.

h. DO—Check transistor insulating washers

and replace if cracked, broken, or missing. Coat washers with insulation compound (silicone) per MIL-S-8660, NSN 6850-00-880-7616.

i. DO—After repair, remove all excess solder. Check for loose wires, screws, and washers which could cause short circuits and burnouts when power is applied to the regulator.

j. DO—Check the regulator cover seal, replace if cracked or missing. Coat the seal with insulation compound (silicone) per MIL-S-8660, NSN 6850-00-880-7616.

k. DO—Apply adhesive 8040-877-9872 to the adjustment access plug or screw.

CHAPTER 2

VAP-AIR MODELS

Section I. INTRODUCTION

2-1. Introduction. Four models were produced by Vap-Air, a division of Vapor Corporation.

Code Ident 80234 (FSCM)

Vapor Corp.
6420 W. Howard St.
Chicago, IL 60648

In 1978, the voltage regulator product line was sold to DC Electronics Corporation.

Code Ident 34904 (FSCM)

DC Electronics Inc.
544 N. Highland Ave.
Aurora, IL 60506

TELEPHONE AC 312844-5170

DC Electronics now provides parts and engineering support for all Vap-Air models. The Vap-Air part numbers for each model are:

26440001-01
26440001-03
26440001-04
26440001-05

2-2. General Inspection. This chapter applies to all Vap-Air models.

a. Regulator Box Assembly (external). Check for missing or stripped cover, connector mount, retainer screws, and voltage adjustment access plug.

Check connectors for signs of arcing, bent, or pushed in pins, broken connectors, and thread damage. Correct deficiencies by utilization of serviceable components from unrepairables or requisitioning components from the manufacturer.

(1) The pin receptacle (J2) is P/N 7064706 FSCM 19207 or MS3102A28-22P FSCM 96906 per MIL-C-5015.

(2) The socket receptacle (J1) is P/N 7064-706 FSCM 19207, an Army number for which

there is no equivalent NSN number. An assembly is available from Bendix.

CODE IDENT 77820 (FSCM)

Bendix Corp.
The Electrical Components
Div.
Sherman Ave.
Sidney, NY 13838

It should be ordered as part number 60-42228-10S; it will arrive as a complete assembly with the shell marked 8701337.

b. Regulator Box Assembly (internal). If water leakage or corrosion is detected, it is possible that extensive damage has been done and the regulator cannot be easily repaired. Components should be performance tested and retained if acceptable. Check for disconnected or burnt wires, missing components, and replace repair as necessary. Carefully remove the transistor mounting plate, noting the position of the screws, washers and rubber insulators. Visually inspect the circuit board for burnt components. Replace the circuit board through cannibalization if burnt components are found. Carefully reinstall the transistor mounting plate.

c. Regulator Verification Check. After performing the above inspection, if the regulator appears to be in good condition, check its performance on a test stand. If the regulator fails this check, proceed to the following component tests.

2-3. Bench Testing. Figures 2-1 and 2-2 show the method for testing NPN transistors; these figures apply to all models in this chapter. If the original transistors are replaced with substitute part numbers, the repaired regulators should be carefully tested to ensure proper operation.

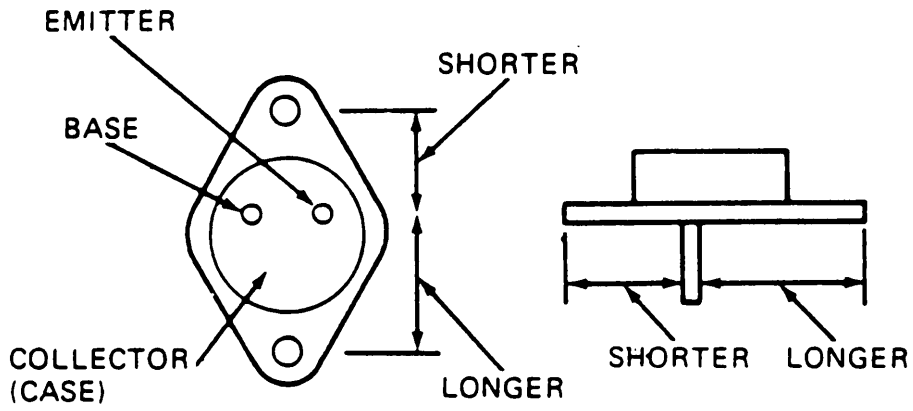

TA 178483

Figure 2-1. NPN transistor (Vap-Air).

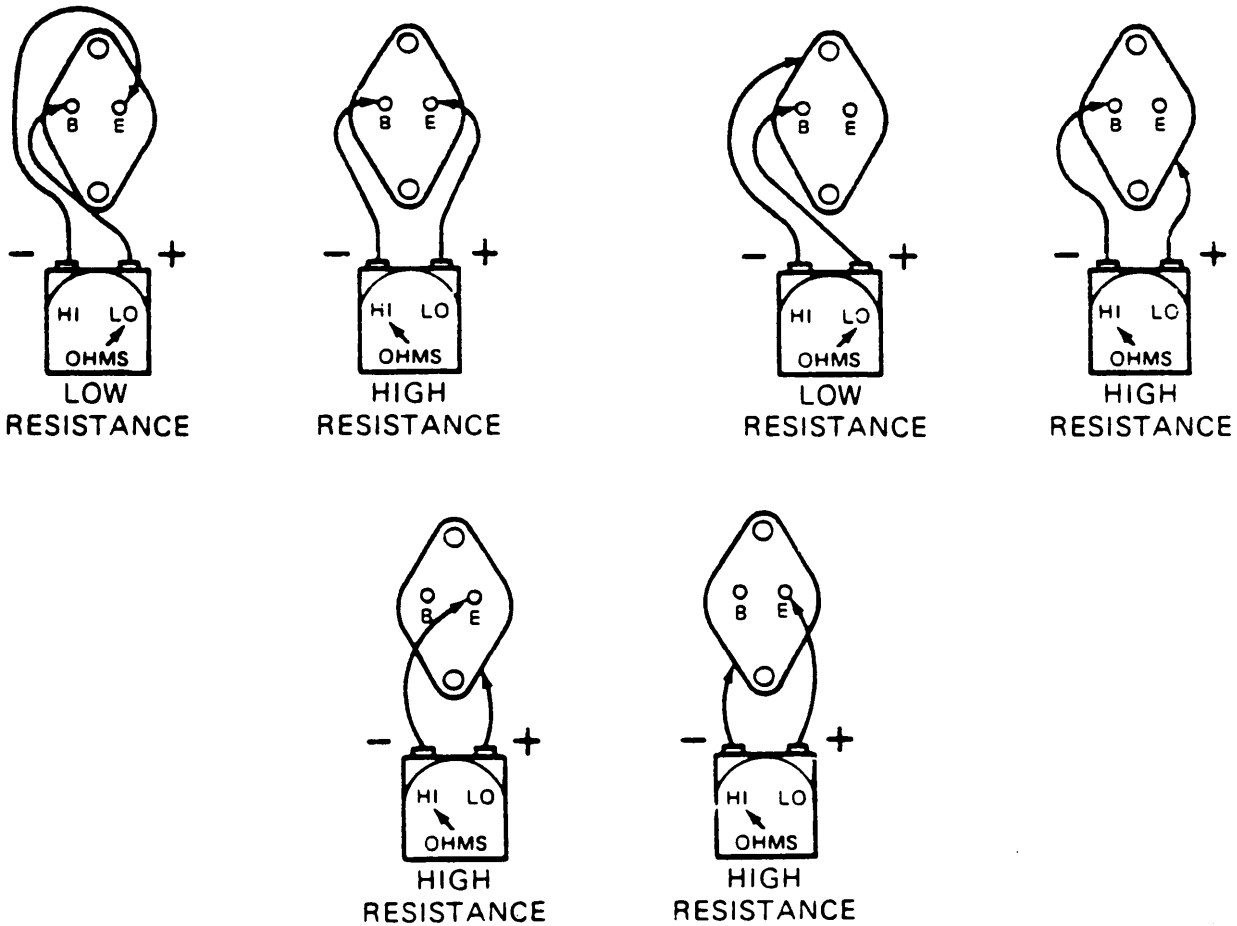

TA 178484

Figure 2-2. Transistor resistance checks (Vap-Air).

Section II. VAP-AIR MODEL 26440001-01

2-4. General. Figures 2-3 and 2-4 show two views of the regulator and its parts. Diode and transistor NSNS and parts numbers with substitute NSNS and part numbers are listed in table 2-1.

2-5. Checkout and Repair.

a. Voltage Adjustment Rheostat (R6) (power disconnected).

(1) Remove voltage adjustment access plug (see fig. 2-3).

(2) Place ohmmeter test probes to terminals of the rheostat (see fig. 2-3).

(3) Rotate rheostat fully clockwise; reading should be less than 5 ohms.

(4) Rotate rheostat fully counterclockwise; reading should be approximately 2500 ohms.

(5) If other readings are obtained, replace rheostat.

b. Transistors.

(1) Carefully remove transistors Q7, Q8, and Q9 (see fig. 2-3).

(2) Position transistor as shown in figure 2-1, and check each separately (see fig. 2-2).

(3) If resistance values differ from the values shown in figure 2-2, replace the transistor according to table 2-1.

NOTE

Transistors Q8 and Q9 are identical and can be interchanged. Transistors Q7 must be replaced by a like item in the same socket (see fig. 2-3).

(4) Check the mica insulating washer between the transistor and mounting plate. Replace if cracked, broken, or missing. Coat washers with insulation compound per MIL-S-8660, NSN 6850-00-880-7616.

c. Diode.

(1) Remove four screws holding transistor mounting plate and move plate to one side.

(2) Place negative ohmmeter probe to the connector side of diode CR6 (see fig. 2-3).

(3) Place positive probe to the circuit board side of CR6. Meter should indicate low resistance.

(4) Reverse probes. Meter should indicate high resistance.

(5) If other readings are obtained, replace diode CR6 (MR1122), NSN 5961-00-103-1519 (see fig. 2-4).

(6) Reinstall transistor mounting plate.

d. Circuit Board. If no faulty components were detected after performance tests a, b, and c above, replace the circuit board.

e. Functional Check. Check the performance of the regulator on the test stand and make final voltage adjustments. Voltage output should read 28 volts. If the regulator does not function properly, perform the following:

(1) Check wires and connections.

(2) Replace circuit board.

(3) Perform bench test procedures.

NOTE

After final repair, check regulator on the test stand.

If the regulator still does not function correctly it will be necessary, if local skills permit, to test each component. All the parts should be checked with an ohmmeter and the capacitors checked with a capacitance meter. The circuit board traces should be checked with an ohmmeter to make sure that there are no cracked traces. Traces with hairline cracks will show good at lower temperatures and will tend to show open circuit at higher temperatures. If the board seems good at room temperature, but the regulator still fails, this could be the cause.

Table 2-1. Replacement Parts List—Model 01

| Ref | P/N | NSN |
|---------|-------------|------------------|
| CR6 | MR1122 | 5961-00-103-1519 |
| Q8 & Q9 | 26316033-20 | 5961-00-133-0396 |
| | 2N5039 | 5961-00-215-5999 |
| | 2N5039 | 5961-00-262-0729 |
| | 8106497-1 | 5961-00-462-3077 |
| | 2N5671 | 5961-00-481-4205 |
| | JAN 2N5038 | 5961-00-858-8960 |
| | 2N3447 | 5961-00-899-9899 |
| | 2N5038 | 5961-00-935-6479 |

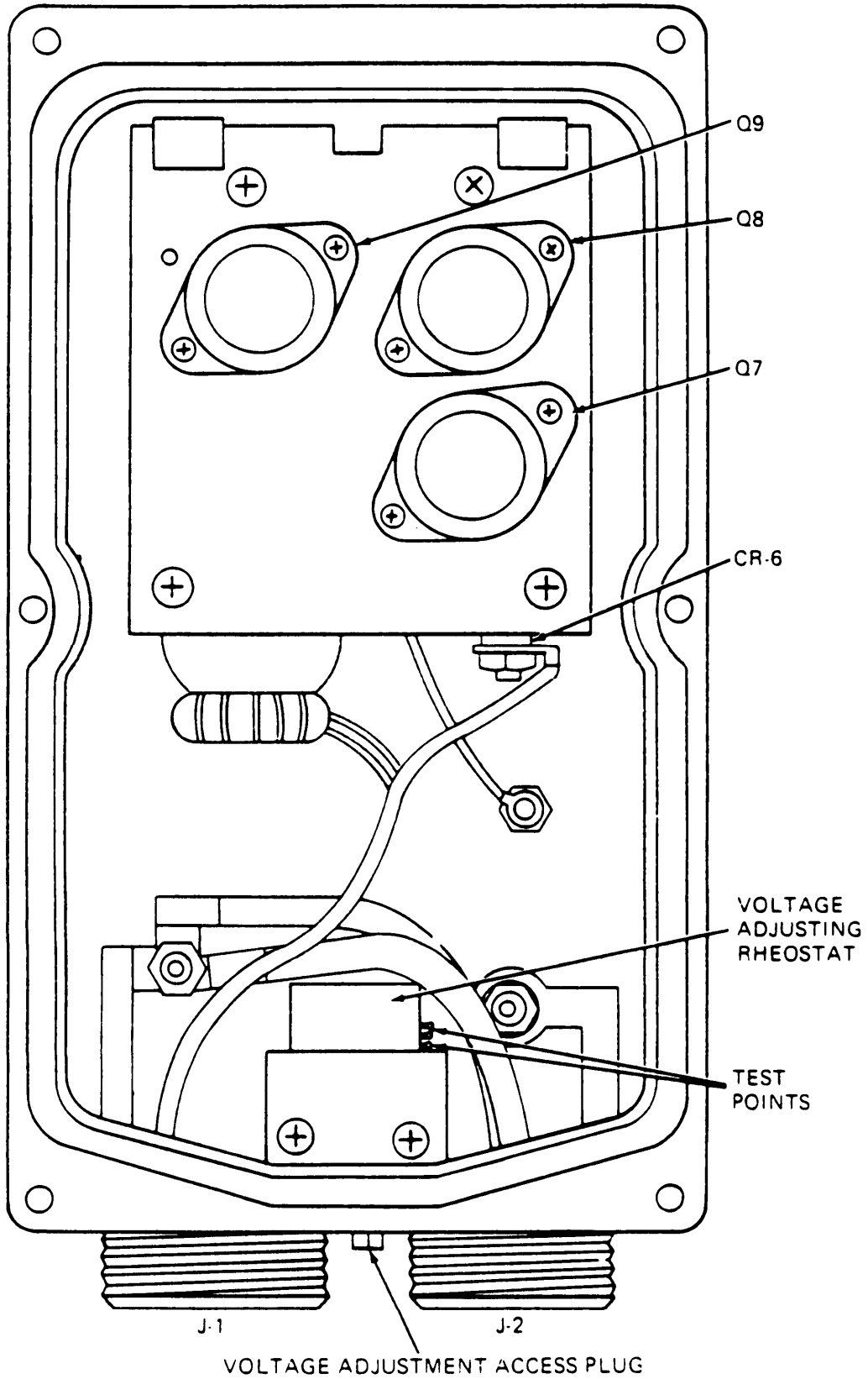
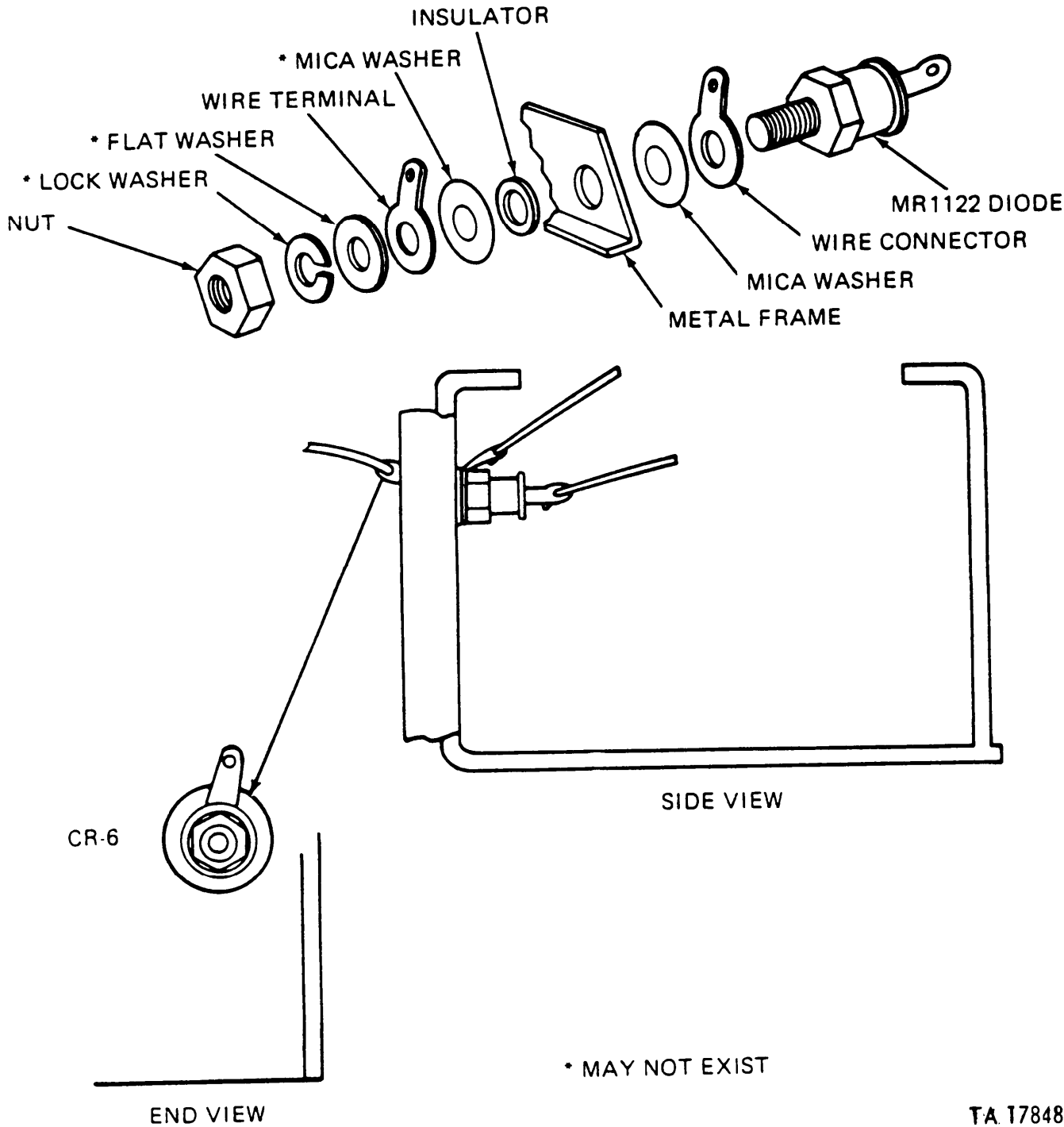

Figure 2-3. Vap-Air model 26440001-01.

TA 178485



TA 178486

Figure 2-4. Diode mounting-model 01.

Section III. VAP-AIR MODEL 2640001-03

2-6. General. Figure 2-5 is a plan view of the regulator with the cover off. Figure 2-6 is an end view of the regulator showing the voltage adjustment point and some test points. Figure 2-7 is a

view of the circuit board. Figure 2-8 is a view of the circuit board showing some of the electrical test points. There are 21 electrical test points. Figure 2-9 is an electrical schematic diagram of

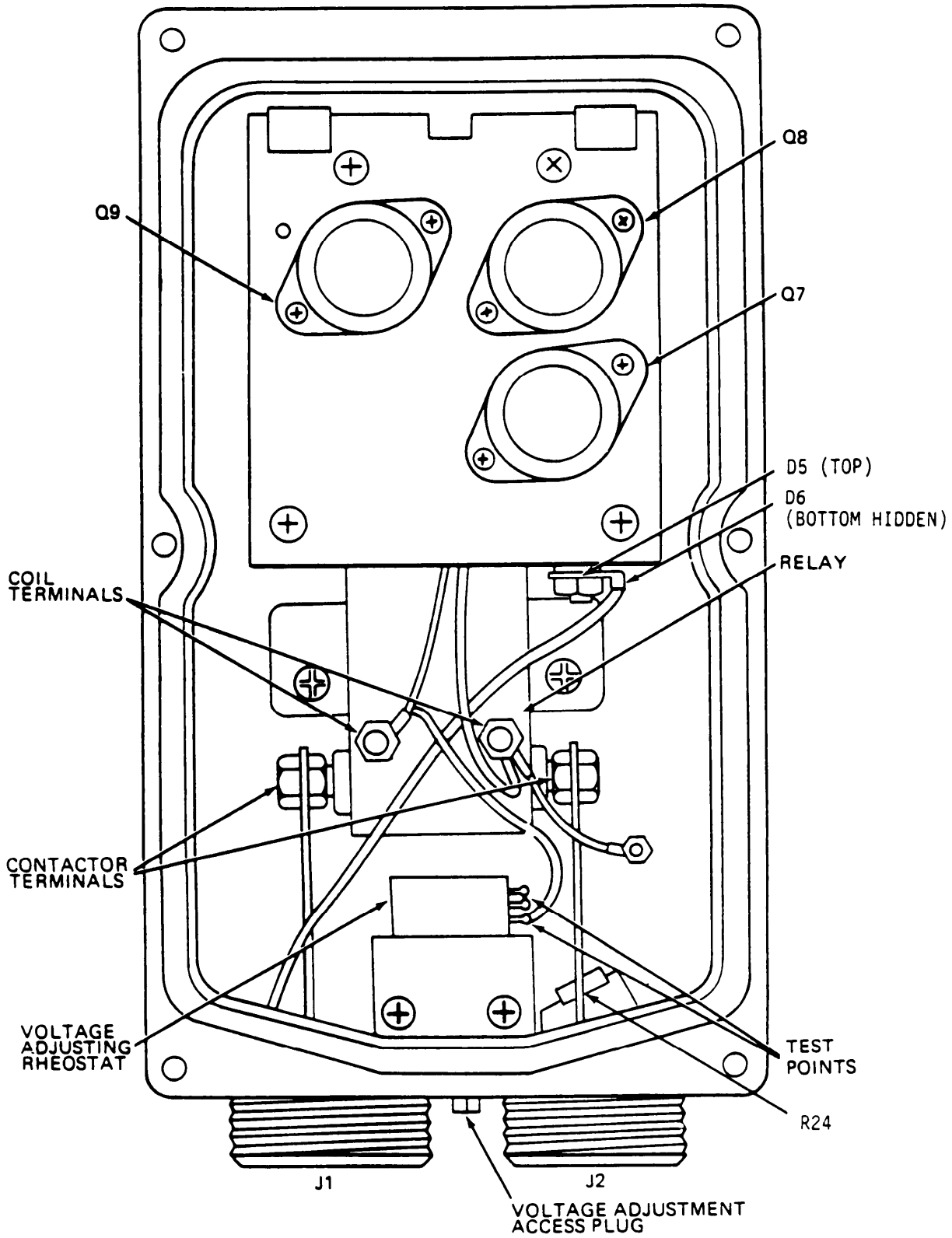

TA 178487

Figure 2-5. Vap-Air model 26440001-03.

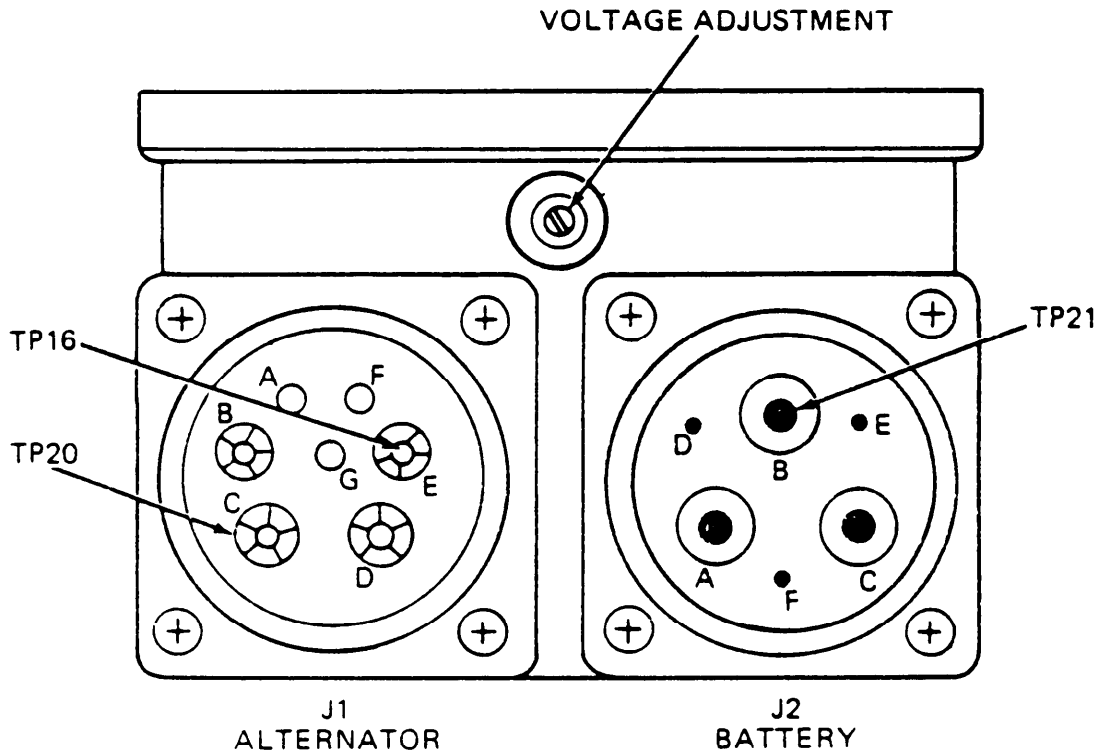

TA 178488

Figure 2-6. End view-model 03.

the regulator. Table 2-2 gives the resistance checks, and table 2-3 gives the voltage checks. Table 2-4 is a diode substitution list.

2-7. Checkout and Repair.

a. Voltage Adjustment Rheostat (R6) (power disconnected).

- (1) Remove voltage adjustment access plug (see fig. 2-5).
- (2) Place ohmmeter test probes to terminals of the rheostat (see fig. 2-5).
- (3) Rotate rheostat fully clockwise; reading should be less than 5 ohms.
- (4) If other readings are obtained, replace rheostat with Vap-Air part number 26527097.

b. Transistors.

- (1) Carefully remove transistors Q7, Q8, and Q9 (see fig. 2-5).
- (2) Position transistors as shown in figure 2-1 and check each separately (see fig. 2-2).
- (3) If resistance values differ from the values shown in fig. 2-2, replace the transistor with a new device. Q7 is Vap-Air part number 26316033-19; Q8 and Q9 are Vap-Air part number 26316033-20.

NOTE

Transistors Q8 and Q9 are identical and can be interchanged. Transistor Q7 must be replaced by a like item in the same socket (see fig. 2-5).

(4) Check the mica insulating washers between the transistors and mounting plate. Replace if cracked, broken or missing. Coat washers with insulation compound per MIL-S-8660, NSN 6850-00-880-7616.

c. Diode.

- (1) Remove four screws holding transistor mounting plate and move plate to one side.
- (2) Place negative ohmmeter probe to the connector side of diode D5 and D6, individually (see figs. 2-5 and 2-9).
- (3) Place positive probe to the circuit board side of D5 and D6, individually. Meter should indicate high resistance.
- (4) Reverse probes. Meter should indicate low resistance.
- (5) If other readings are obtained, replace diodes D5 and D6, NSN 5961-00-103-1519 (see fig. 2-5).
- (6) Reinstall transistor mounting plate.

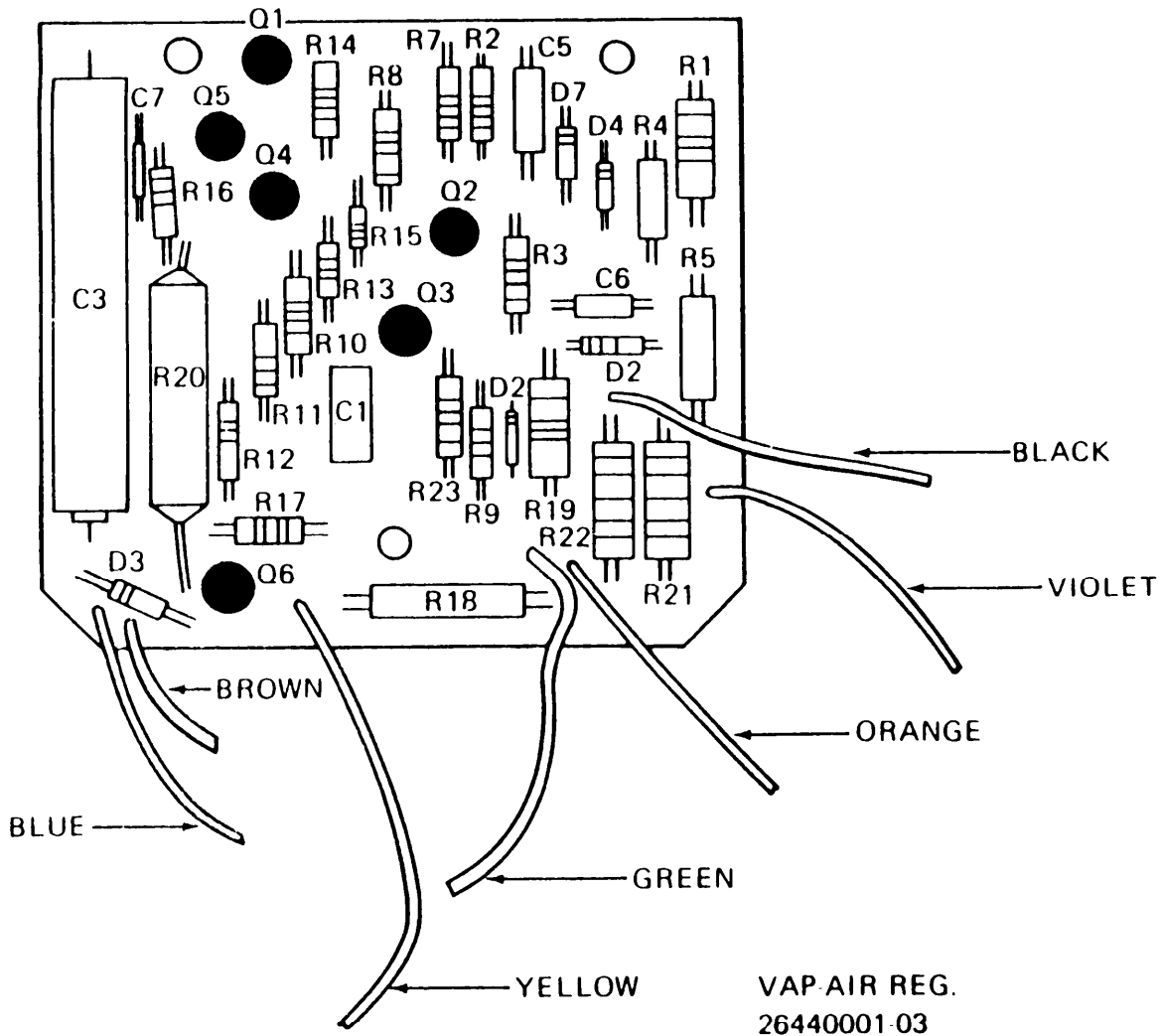

LEGEND

| | | | | | |
|-----|------------------|-----|------------------|----|--|
| R1 | 270 ohms, 1W | R13 | 1.8K ohms, 1/2 W | C1 | .01 MFD |
| R2 | 680 ohms, 1/2 W | R14 | 1.8K ohms, 1/2 W | C2 | .1 MFD (BELOW POWER TRANSISTOR HEAT SINK) |
| R3 | 1.5K ohms, 1/2 W | R15 | 390 ohms, 1/4 W | C3 | 37 MFD |
| R4 | 680 ohms, 1/2 W | R16 | 1K ohms, 1/2 W | C4 | .1 MMFD (BELOW POWER TRANSISTOR HEAT SINK) |
| R5 | 270 ohms, 1W | R17 | 470 ohms, 1/2 W | C5 | 6.8 MFD |
| R6 | VAR 100 ohms | R18 | 390 ohms, 1W | C6 | 1 MFD |
| R7 | 1.5K ohms, 1/2 W | R19 | 470 ohms, 1/2 W | C7 | .22 MFD |
| R8 | 12K ohms, 1/2 W | R20 | 18 ohms, 2W | | |
| R9 | 10K ohms, 1/2 W | R21 | 27 ohms, 1W | | |
| R10 | 1K ohms, 1/2 W | R22 | 27 ohms, 1W | | |
| R11 | 6.8K ohms, 1/2 W | R23 | 5.6K ohms, 1/2 W | | |
| R12 | 1K ohms, 1/2 W | R24 | .39 ohms, 1W | | |

TA178489

Figure 2-7. Circuit board-model 03.

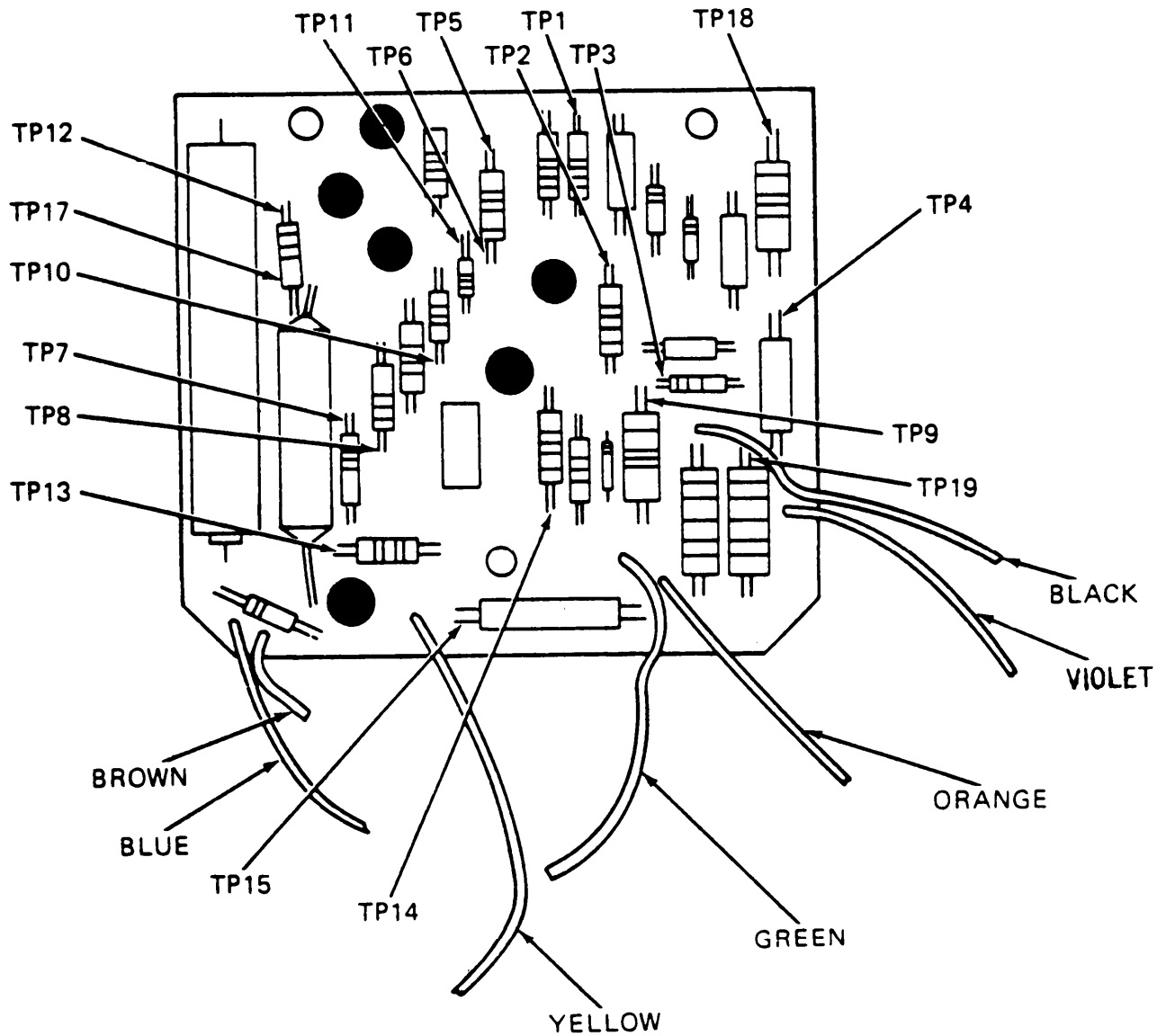

TA178490

Figure 2-8. Test points—model 03.

d. Relay.

(1) Place ohmmeter probes across relay coil terminals (see fig. 2-5). Meter should read approximately 60 ohms.

(2) Place ohmmeter probes across contactor terminals (see fig. 2-5). Meter should read infinity (open circuit).

(3) If other readings are obtained, replace relay with NSN 2920-00-735-9542.

e. Detailed Circuit Checks.

(1) Table 2-2 contains "power off" resist-

ance checks of the circuit (see figs. 2-6 and 2-8 for test points).

(2) Table 2-2 contains "power on" voltage checks of the circuit (see figs. 2-6 and 2-8 for test points).

f. Functional Check. Check the performance of the regulator on the test stand and make final voltage adjustments. Voltage output should read 28 volts. If the regulator does not function properly, perform the following:

(1) Check wires and connections.

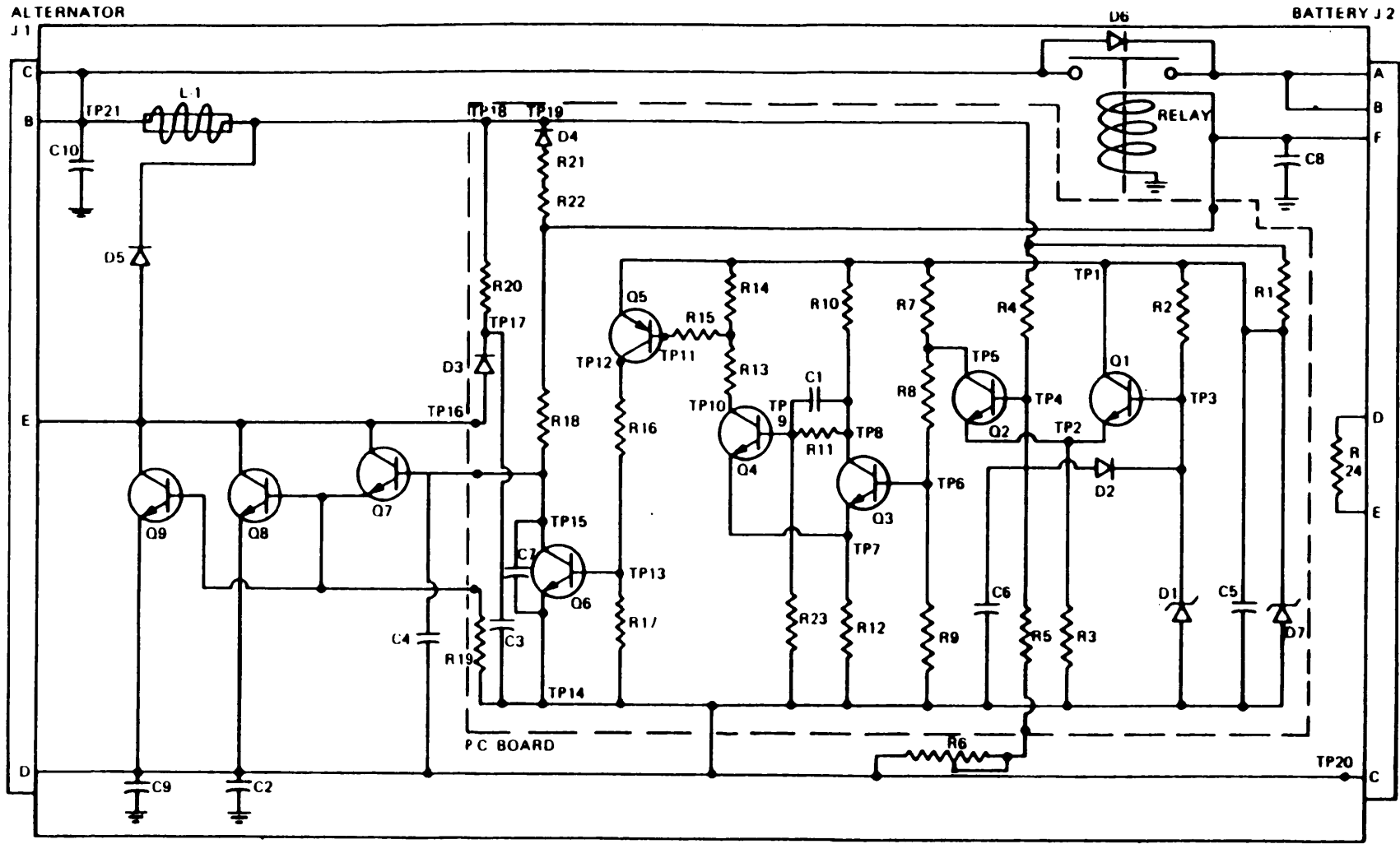

TA178491

Figure 2-9. Schematic diagram—model 03.

Table 2-2. Resistance Checks (Power Off) — Model 03

NOTE

REMOVE TRANSISTORS Q7, Q8, Q9 FROM THE CIRCUIT AND ADJUST R6 FULLY
CLOCKWISE MAKING THE CHECKS.

| Red for TS352 Negative | Black for TS352 Positive | Resistance (OHMS) | Resistance Scale (TS352 Meter) | Component | NSN |
|---------------------------|-----------------------------|----------------------|-----------------------------------|-----------------------------|--------------------------------------|
| TP1 | TP2 | 2000-3000 | R x 10 | TRANSISTOR Q1 2N2405 | 5960-00-730-3284 |
| TP2 | TP1 | 150-250 | | | |
| TP2 | TP3 | 150-250 | | | |
| TP3 | TP2 | 2000-3000 | | | |
| TP3 | TP1 | 350-550 | | | |
| TP1 | TP3 | 100-250 | | | |
| TP5 | TP2 | 1500-2500 | R x 10 | TRANSISTOR Q1 2N2405 | 5961-00-730-3284 |
| TP2 | TP5 | 1700-2500 | | | |
| TP2 | TP4 | 150-250 | | | |
| TP4 | TP2 | 1500-2500 | | | |
| TP4 | TP5 | 1500-2000 | | | |
| TP5 | TP4 | 150-250 | | | |
| TP7 | TP8 | 1000-2000 | R x 10 | TRANSISTOR Q3 2N2405 | 5961-00-730-3284 |
| TP7 | TP6 | 150-250 | | | |
| TP6 | TP7 | 4000-10,000 | | | |
| TP6 | TP8 | 4000-10,000 | | | |
| TP8 | TP6 | 150-250 | | | |
| TP7 | TP10 | 3000-5000 | | | |
| TP10 | TP7 | 1500-2500 | R x 10 | TRANSISTOR Q4 2N2405 | 5961-00-730-3284 |
| TP7 | TP9 | 150-250 | | | |
| TP9 | TP7 | 3000-5000 | | | |
| TP9 | TP10 | 3500-5500 | | | |
| TP10 | TP9 | 150-250 | | | |
| TP1 | TP12 | 300-800 | | | |
| TP12 | TP1 | 2000-4000 | R x 10 | TRANSISTOR Q5 2N3638A | 5961-00-912-9008 |
| TP12 | TP11 | 4000-6000 | | | |
| TP11 | TP12 | 500-700 | | | |
| TP11 | TP1 | 500-700 | | | |
| TP1 | TP11 | 1000-2000 | | | |
| TP14 | TP15 | 250-350 | | | |
| TP15 | TP14 | 400-500 | R x 10 | TRANSISTOR Q6 2N2405 | 5961-00-730-3284 |
| TP14 | TP13 | 150-300 | | | |
| TP13 | TP14 | 400-500 | | | |
| TP13 | TP15 | 800-1200 | | | |
| TP15 | TP13 | 150-250 | | | |
| TP3 | TP4 | 15-35 | | | |
| TP4 | TP3 | OVER 500 | 1N936B | 5961-00-879-7145 | |
| TP16 | TP17 | OVER 500 | R x 1 | DIODE D3 | |
| TP17 | TP16 | 15-30 | | 1N4002 or 1N2482 | 5961-00-880-4783 5961-00-833-9050 |
| TP18 | TP19 | 15-30 | R x 1 | DIODE D4 | |
| TP19 | TP18 | OVER 500 | | 1N4002 or 1N2482 | 5961-00-880-4783 5961-00-833-9050 |
| TP16 | TP18 | OVER 500 | R x 1 | DIODE D4 | |
| TP18 | TP16 | 15-25 | | 1N4002 or 1N2482 | 5961-00-880-4783 5961-00-833-9050 |
| TP20 | TP12 | OVER 500 | R x 1 | DIODE D5 | |
| TP21 | TP20 | 15-25 | | MR1122 | 5961-00-103-1519 |
| TP20 | TP12 | OVER 500 | R x 1 | DIODE D6 | |
| TP21 | TP20 | 15-25 | | MR1122 | 5961-00-103-1519 |

- (2) Replace circuit board, Vap-Air part number 26644321.
- (3) Perform bench test procedures.

NOTE
After final repair, check regulator on the test stand.

Table 2-3. Voltage Checks (Power On)-Model 03

NOTE

REMOVE TRANSISTORS Q7, Q8, AND Q9 FROM CIRCUIT AND ADJUST R6 FULLY COUNTERCLOCKWISE BEFORE MAKING THESE CHECKS. TO PREVENT A SHORT CIRCUIT, SLIDE TRANSISTOR HEAT SINK IN SLOT ON LEFT SIDE OF THE REGULATOR.

| Red for TS352 Positive | Black for TS352 Negative | Voltage* (Volts) | Regulator Applied Voltage | Component | NSN |
|------------------------|--------------------------|------------------|---------------------------|---------------------|--------------------------------------|
| TP1 | J1-PIN D | 15.5 | 20.0 | DIODE D7 1N4745 | Cannibalize |
| TP2 | " " | 8.2 | " | DIODE D1 | |
| TP3 | " " | 8.8 | " | **1N936 DIODE D1 | 5961-00-811-3752 |
| TP4 | " " | 6.0 | " | **1N936 | 5961-00-811-3752 |
| TP5 | " " | 1.7 | " | | |
| TP6 | " " | 6.0 | " | | |
| TP7 | " " | 5.5 | " | | |
| TP8 | " " | 8.2 | " | | |
| TP9 | " " | 3.5 | " | | |
| TP10 | " " | 15.0 | " | | |
| TP11 | " " | 15.0 | " | | |
| TP12 | " " | 0.0 | " | | |
| TP13 | " " | 0.0 | " | | |
| *TP14 | " " | 0.0 | " | | |
| TP15 | " " | 15.0 | " | | |
| TP16 | " " | 20.0 | " | | |
| TP17 | " " | 20.0 | " | | |
| TP18 | " " | 20.0 | " | | |
| TP19 | " " | 20.0 | " | | |
| TP20 | " " | 20.0 | " | | |
| TP21 | " " | 20.0 | " | | |
| TP1 | J1-PIN D | 16.0 | 30.0 | DIODE D7 IN4745 | Cannibalize |
| TP2 | " " | 8.3 | | DIODE D1 | 5961-00-879-7145 |
| TP3 | " " | 9.0 | | **1N936 DIODE D1 | 5961-00-811-3752 5961-00-811-3752 |
| TP4 | " " | 8.6 | " | **1N936 | |
| TP5 | " " | 14.0 | " | | |
| TP6 | " " | 6.3 | " | | |
| TP7 | " " | 5.9 | " | | |
| TP8 | " " | 8.6 | " | | |
| TP9 | " " | 3.7 | " | | |
| TP10 | " " | 15.5 | " | | |
| TP11 | " " | 15.5 | " | | |
| TP12 | " " | 0.0 | " | | |
| TP13 | " " | 0.0 | " | | |
| TP14 | " " | 0.0 | " | | |
| TP14 | " " | 0.0 | " | | |
| TP15 | " " | 18.5 | " | | |
| TP16 | " " | 30.0 | " | | |
| TP17 | " " | 30.0 | " | | |
| TP18 | " " | 30.0 | " | | |
| TP19 | " " | 30.0 | " | | |
| TP20 | " " | 30.0 | " | | |
| TP21 | " " | 30.0 | " | | |

*Values may vary $\pm 5\%$
**See Table 3-4 for substitutes

Table 2-4. Substitutes for D1-Model 03

| P/N | NSN |
|--------------|------------------|
| 1N936 | 5961-00-811-3752 |
| 1N936A | 5961-00-892-3195 |
| 1N936B | 5961-00-879-7145 |
| JAN 1N937B | 5961-00-226-5134 |
| JANTX 1N937B | 5961-00-484-5035 |
| 1N938 | 5961-00-620-9770 |
| 1N938A | 5961-00-078-0628 |
| JAN 1N938B | 5961-00-892-0889 |
| JANTX 1N938B | 5961-00-484-5036 |
| JAN 1N939B | 5961-00-852-5174 |

If the regulator still does not function correctly it will be necessary, if local skills permit, to test each component. All the parts should be checked with an ohmmeter and the capacitors checked with a capacitance meter. The circuit board traces should be checked with an ohmmeter to make sure that there are no cracked traces. Traces with hair-line cracks will show good at lower temperatures and will tend to show open circuit at higher temperatures. If the board seems good at room temperature, but the regulator still fails, this could be the cause.

Section IV. VAP-AIR MODEL 26440001-04

2-8. General. Figure 2-10 is a plan view of the regulator with the cover off. Figure 2-11 is an end view of the regulator showing the receptacles and the voltage adjustment points. Figure 2-12 is an exploded view of the diode mounting. Figure 2-13 is a relay location. Figure 2-14 is a view of the circuit board and transistor heat sink. Figure 2-15 is a view of the circuit board showing the electrical test points. There are 12 electrical test points. Figure 2-16 is an electrical schematic diagram of the regulator. Table 2-5 lists the resistance checks, and table 2-6 lists the voltage checks. Table 2-7 is a transistor substitution list.

2-9. Checkout and Repair.

a. Voltage Adjustment Rheostat (Rz) (Power Disconnected).

(1) Place ohmmeter test probes to terminals of the rheostat (see fig. 2-10).

(2) Rotate rheostat fully clockwise, reading should be approximately 250 ohms.

(3) Rotate rheostat fully counterclockwise, reading should be less than 5 ohms.

(4) If other readings are obtained, replace rheostat.

b. Transistors.

(1) Remove transistors Q4 and Q5 (see fig. 2-10).

(2) Position transistors as shown in figure 2-1, and check them separately (see fig. 2-2).

(3) If resistance values differ from the values shown in figure 2-2, replace the transistors through cannibalization or requisition transistor Q4, Vap-Air part number 26316033-12 (2N3441), NSN 5961-00-054-4141, or transistor Q5, Vap-Air P N 26316033-70 (2N3773), NSN 5961-00-929-5014 (see table 2-7 for substitutes).

(4) Check the mica insulating washers between the transistors and mounting plate. Replace

if cracked, broken or missing. Coat washers with insulation compound per MIL-S-8660, NSN 6850-00-880-7616.

c. Diode.

(1) Remove four screws holding transistor and circuit board mounting plate, and move plate to one side.

(2) Place negative ohmmeter probe to the top side of diode D4 (see fig. 2-12).

(3) Place positive probe to the bottom of D4. Meter should indicate low resistance.

(4) Reverse probes. Meter should indicate high resistance.

(5) If other readings are obtained replace diode D4 (MR1122), NSN 5961-00-103-1519 (see fig. 2-12).

d. Relay.

(1) Place ohmmeter probes across relay coil terminals (see fig. 2-13).

(2) Place ohmmeter probes across terminals (see fig. 2-13). Meter should read infinity (open circuit).

(3) If other readings are obtained, replace relay, NSN2920-00-735-9542.

(4) Reinstall transistor and circuit board mounting plate.

e. Detailed Circuit Checks.

(1) Table 2-5 contains "power off" resistance checks of the circuit (see fig. 2-15 for test points).

(2) Table 2-6 contains "power on" voltage checks of the circuit (see fig. 2-15 for test points).

f. Functional Check. Check the performance of the regulator on the test stand and make final voltage adjustments. Voltage output should read 28 volts. If the regulator does not function properly, perform the following:

(1) Check wires and connections.

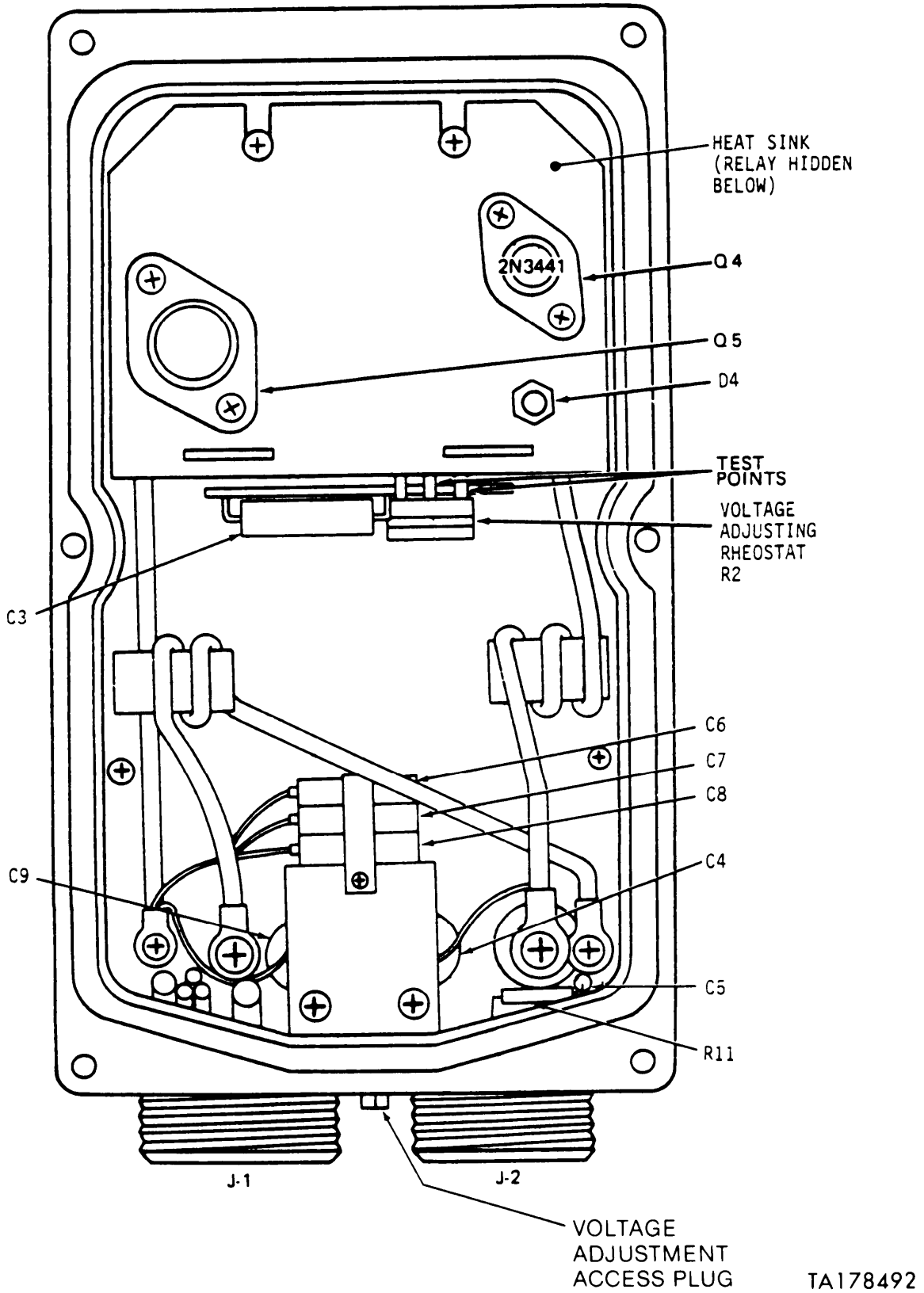
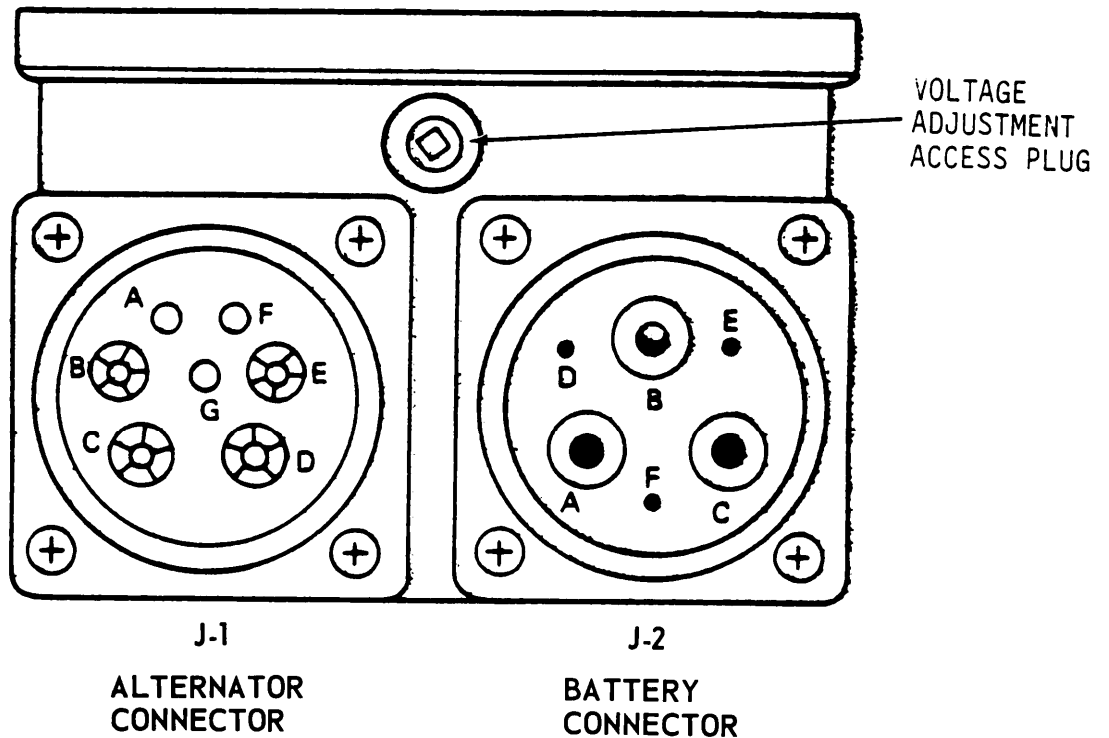

Figure 2-10. Vap-Air model 26440001-04.



TA178493

Figure 2-11. End view—model 04.

(2) Replace circuit board, Vap-Air part number 27134372.

(3) Perform bench test procedures.

NOTE

After final repair, check regulator on the test stand.

Table 2-5. Resistance Checks (Power Off)—Model 04

NOTE

REMOVE TRANSISTORS Q4, Q5 FROM THE CIRCUIT AND ADJUST R2 FULLY CLOCKWISE BEFORE MAKING THESE CHECKS.

| Red for TS352 Negative | Black for TS352 Positive | Resistance (OHMS) | Resistance Scale (TS352 Meter) | Component | NSN |
|------------------------|--------------------------|-------------------|--------------------------------|--------------------------|------------------|
| TP1 | TP2 | 250-500 | R x 10 | TRANSISTOR Q3 2N2222A | 5961-00-951-8757 |
| TP2 | TP1 | 750-1500 | | | |
| TP1 | TP3 | 130-400 | | | |
| TP3 | TP1 | 1500-5000 | | | |
| TP2 | TP3 | 150-400 | | | |
| TP3 | TP2 | 700-1500 | | | |
| TP5 | TP4 | 1000-3500 | R x 10 | TRANSISTOR Q2 2N3638A | 5961-00-912-9008 |
| TP4 | TP5 | 3000-7000 | | | |
| TP6 | TP5 | 150-300 | | | |
| TP5 | TP6 | 2000-5000 | | | |
| TP6 | TP4 | 150-300 | R x 100 | | |
| TP4 | TP6 | 7,500-12,000 | | | |

Table 2-5. Resistance Checks (Power Off)—Model 04—continued

| Red for TS352 Positive | Black for TS352 Negative | Resistance (OHMS) | Resistance Scale (TS352 Meter) | Component | NSN |
|------------------------|--------------------------|-------------------|--------------------------------|--------------------------|------------------|
| TP7 | TP8 | 3000-5000 | R x 100 | TRANSISTOR Q1 2N2222A | 5961-00-951-8757 |
| TP8 | TP7 | 10,000-20,000 | | | |
| TP8 | TP9 | 1500-2500 | | | |
| TP9 | TP8 | 5000-7000 | | | |
| TP7 | TP9 | 1500-2500 | | | |
| TP9 | TP7 | 10,000-20,000 | | | |
| TP10 | TP11 | 15-25 | R x 1 | DIODE D3 1N5402 | 5961-00-761-4631 |
| TP11 | TP10 | OVER 1000 | | | |
| TP2 | TP12 | 15-25 | R x 1 | DIODE D2 1N2482 | 5961-00-833-9050 |
| TP12 | TP2 | OVER 1000 | | | |
| J1-PIN B | J1-PIN E | 5000-15,000 | R x 100 | DIODE D4 MR1122 | 5961-00-103-1519 |
| J1-PIN E | J1-PIN B | 25,000-50,000 | | | |

Table 2-6. Voltage Checks (Power On)—Model 04

NOTE

REMOVE TRANSISTORS Q4, Q5 FROM THE CIRCUIT AND ADJUST R2 FULLY CLOCKWISE BEFORE MAKING THESE CHECKS.

| Red for TS352 Positive | Black for TS352 Negative | Voltage* (Volts) | Regulator Applied Voltage | Component | NSN |
|------------------------|--------------------------|------------------|---------------------------|--|--|
| TP1 | J1-PIN D | 1.2 | 20.0 | DIODE D1 1N756A 1N756A JANTX 1N756A 1N959A | 5961-00-068-2001 5961-00-845-6458 5961-00-105-5734 5961-00-400-1992 |
| TP2 | " " | 0.0 | " | | |
| TP3 | " " | 0.0 | " | | |
| TP4 | " " | 0.0 | " | | |
| TP5 | " " | 20.0 | " | | |
| TP6 | " " | 20.0 | " | | |
| TP7 | " " | 20.0 | " | | |
| TP8 | " " | 8.2 | " | | |
| TP9 | " " | 8.0 | " | | |
| TP10 | " " | 19.0 | " | | |
| TP11 | " " | 20.0 | " | | |
| TP12 | " " | .6 | " | | |
| TP1 | " " | .05 | 30.0 | DIODE D1 IN2482 | 5961-00-833-9050 |
| TP2 | " " | 0.0 | " | | |
| TP3 | " " | .8 | " | | |
| TP4 | " " | 30.0 | " | | |
| TP5 | " " | 30.0 | " | | |
| TP6 | " " | 29.5 | " | | |
| TP7 | " " | 8.5 | " | | |
| TP8 | " " | 8.4 | " | | |
| TP9 | " " | 9.2 | " | | |
| TP10 | J1-PIN D | 29.0 | 30.0 | | |
| TP11 | " " | 30.0 | " | | |
| TP12 | " " | .65 | " | | |

*Values may vary ± 5%

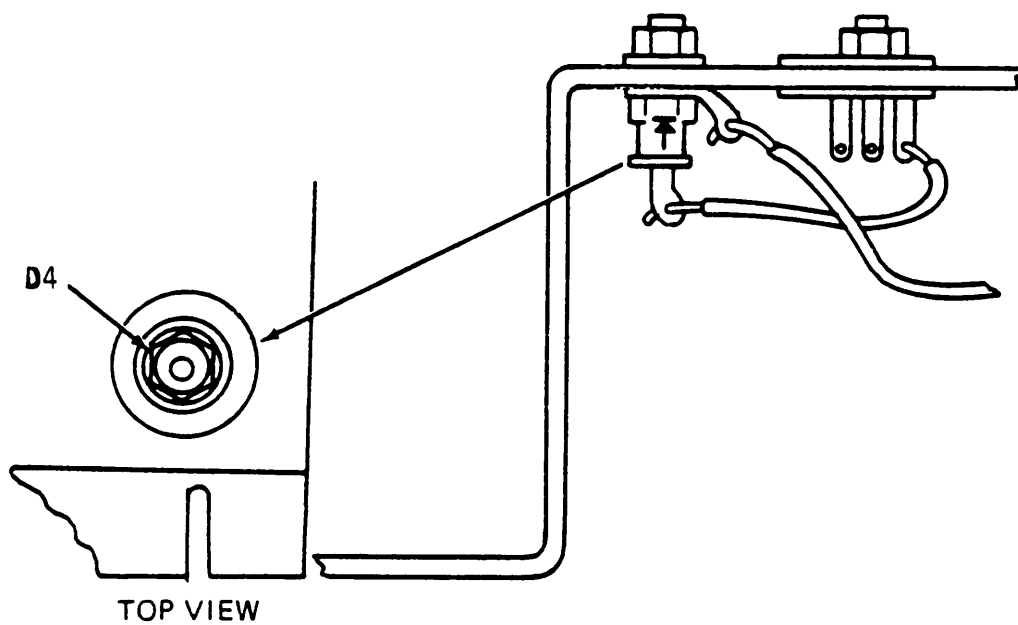
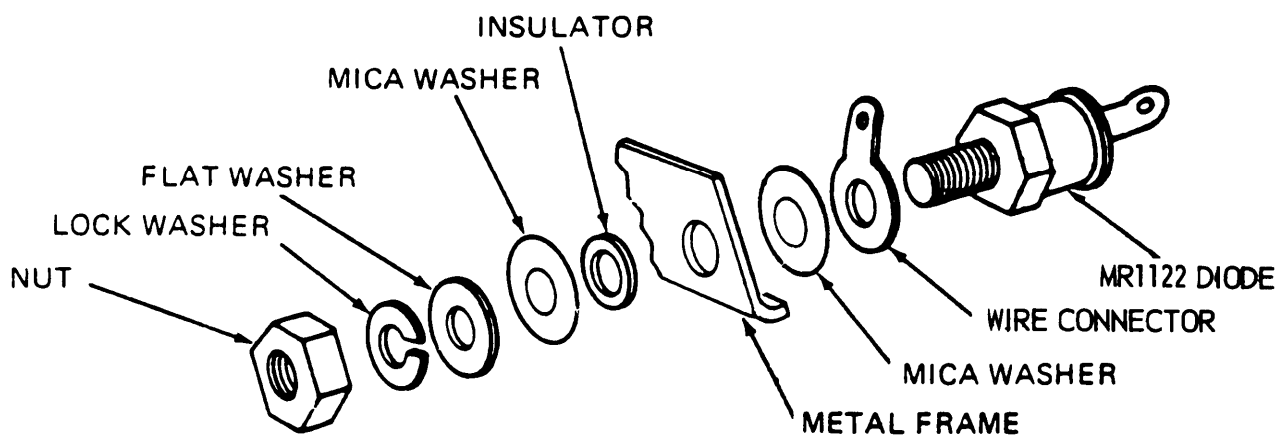

TA178494

Figure 2-12. Diode mounting-model 04.

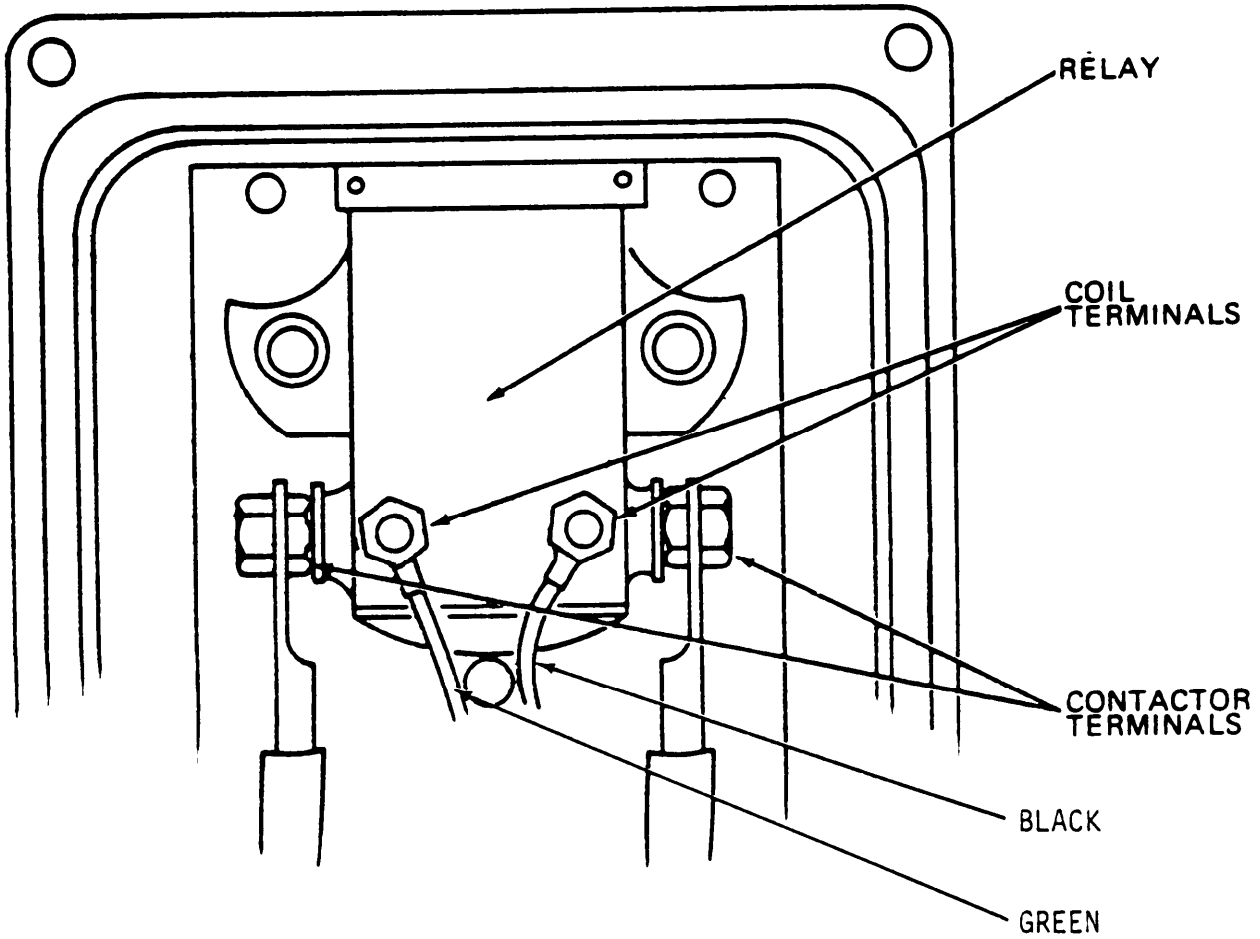

TA178495

Figure 2-13. Relay location-model 04.

Table 2-7. Substitutes for transistor Q5-Model 04

| P/N | NSN |
|---------------------|------------------|
| 2N3773 | 5961-00-327-8280 |
| 2N3773 | 5961-00-929-5014 |
| JAN 2N3771 | 5961-00-431-7863 |
| JANTX 2N3771 | 5961-00-758-5816 |
| 2N3772 | 5961-00-438-2156 |
| 2N3772 | 5961-00-854-6759 |
| 2N3772 | 5961-00-864-7527 |
| JAN 2N3772 | 5961-00-403-2566 |
| JA 5961-00-760-1302 | 5961-00-760-1302 |
| 2N5038 | 5961-00-935-6479 |
| JAN 2N5038 | 5961-00-858-8960 |
| JANTX 2N5038 | 5961-00-359-5752 |
| 2N5039 | 5961-00-215-5999 |
| 2N5039 | 5961-00-262-0729 |
| JANTX 2N5039 | 5961-01-033-0822 |
| 2N5671 | 5961-00-481-4205 |
| JAN 2N5671 | 5961-01-019-6400 |
| 2N5672 | 5961-00-523-9171 |
| 2N5672 | 5961-00-003-0584 |

Table 2-7. Substitutes for transistor Q5-Model 04—continued

| P/N | NSN |
|--------------|------------------|
| JANTX 2N5672 | 5961-00-017-0990 |
| 2N6258 | 5961-00-255-9986 |

If the regulator still does not function correctly it will be necessary, if local skills permit, to test each component. All the parts should be checked with an ohmmeter and the capacitors checked with a capacitance meter. The circuit board traces should be rechecked with an ohmmeter to make sure that there are no cracked traces. Traces with hair-line cracks will show good at lower temperatures and will tend to show open circuit at higher temperatures. If the board seems good at room temperature, but the regulator still fails, this could be the cause.

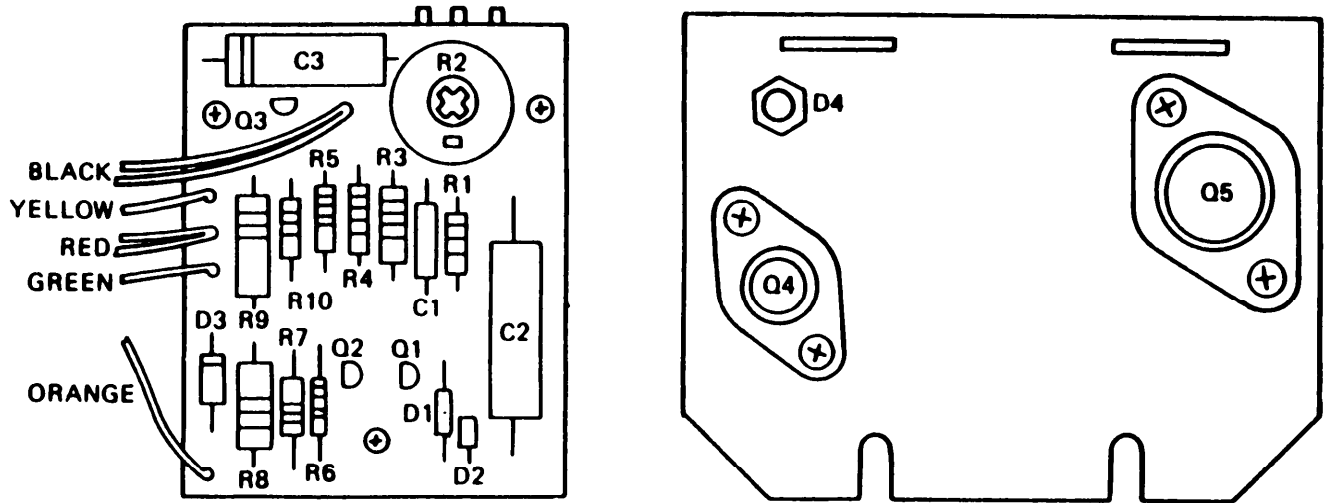

LEGEND

| | | | | | | | |
|----|---------|-----|-------------------|----|-----------|----|---------|
| Q1 | 2N222A | R1 | 13.2K ohms, 1/2W | C1 | 2.2 MFD | D1 | 1N756A |
| Q2 | 2N3638A | R2 | VAR. 250 ohms, 2W | C2 | 82 MFD | D2 | 1N2482 |
| Q3 | 2N2222A | R3 | 62.1K ohms, 1/2W | C3 | 8.2 MFD | D3 | 1N2482 |
| Q4 | 2N3441 | R4 | 5.1K ohms, 1/2W | C4 | 8MFD | D4 | MR 1122 |
| Q5 | 2N3773 | R5 | 8.2K ohms, 1/2W | C5 | .0047 MFD | | |
| | | R6 | 3.3K ohms, 1/2W | C6 | .47 MFD | | |
| | | R7 | 4.7K ohms, 1/2W | C7 | .47 MFD | | |
| | | R8 | 300 ohms, 1W | C8 | .47 MFD | | |
| | | R9 | 300 ohms, 1W | C9 | 8 MFD | | |
| | | R10 | 1K ohms, 1/2W | | | | |
| | | R11 | .39 ohms, 1W | | | | |

TA178496

Figure 2-14. Circuit board and transistor heat sink-model 04.

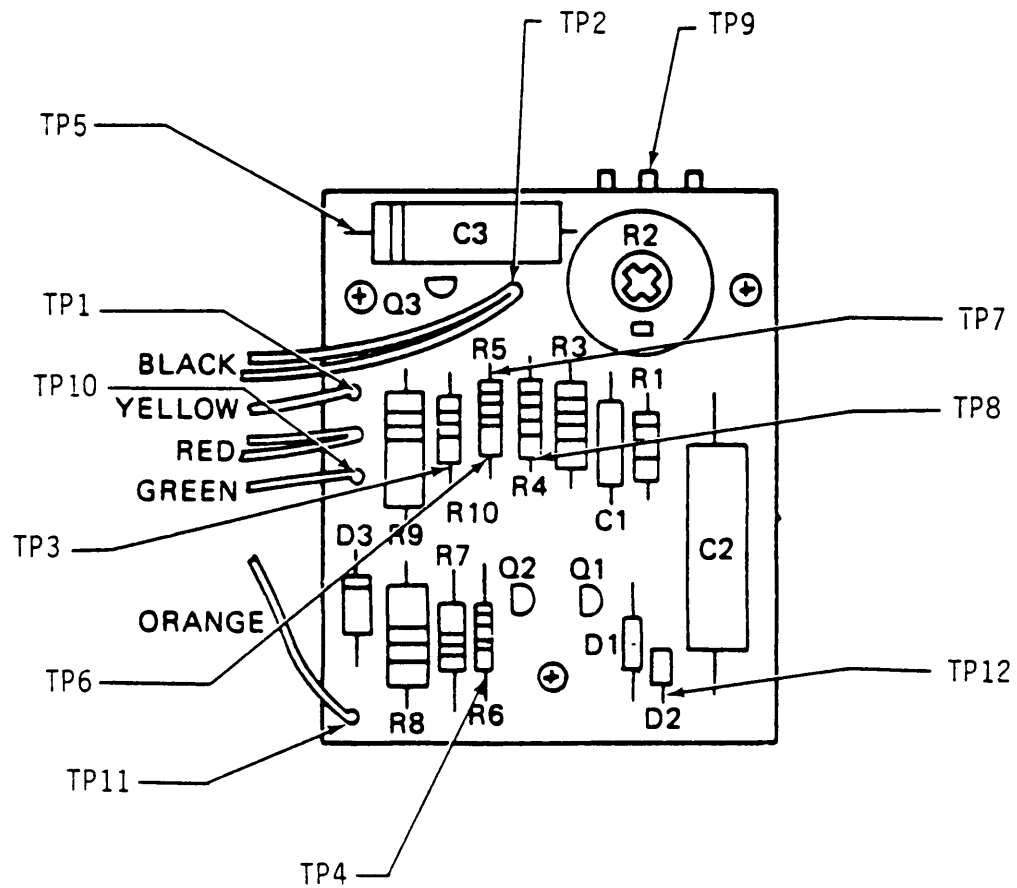

TA178497

Figure 2-15. Test points-model 04.

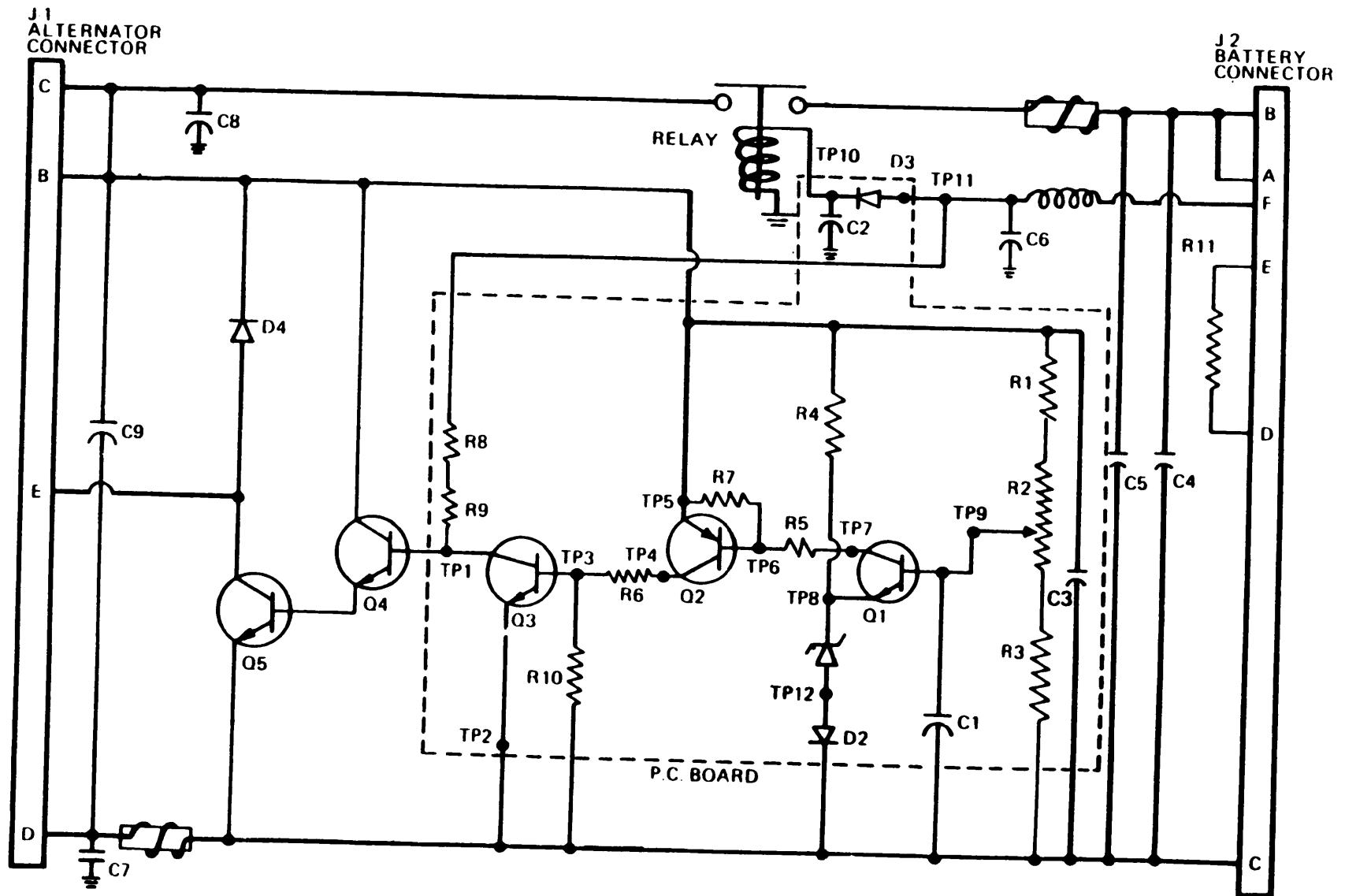

TA178498

Figure 2-16. Schematic diagram—model 04.

Section V. VAP-AIR MODEL 26440001-05

2-10. General. Figure 2-17 is a plan view of the regulator with the cover off. Figure 2-18 is the end view of the regulator showing the receptacles and the voltage adjustment point. Figure 2-19 is an exploded view of the diode mounting. Figure 2-20 is a relay location drawing. Figure 2-21 is a view of the circuit board and transistor heat sink. Figure 2-22 is a view of the circuit board showing the electrical test points. There are 12 electrical test points. Figure 2-23 is an electrical schematic diagram of the regulator. Table 2-8 lists the resistance checks. Table 2-9 lists the voltage checks. Table 2-10 is a transistor substitution list.

2-11. Checkout and Repair.

a. Voltage Adjustment Rheostat (R2) (power disconnected).

(1) Place ohmmeter test probes to the violet and brown wire terminals of the rheostat (see fig. 2-17).

(2) Rotate rheostat fully clockwise, reading should be approximately 250 ohms.

(3) Rotate rheostat fully counterclockwise, reading should be less than 5 ohms.

(4) If other readings are obtained, replace rheostat.

b. Transistors.

(1) Remove transistors Q4 and Q5 (see fig. 2-17).

(2) Position transistors as shown in figure 2-1, and check each separately (see fig. 2-2).

(3) If resistance values differ from the above, replace the transistors through cannibalization or requisition transistor Q4, Vap-Air part number 26316033-12 (2N3441), NSN 5961-00-054-4141, or transistor Q5, Vap-Air part number 26316033-70 (2N3773), NSN 5961-00-929-5014 (see table 2-10 for substitutes).

(4) Check the mica insulating washers between the transistors and mounting plate. Replace if cracked, broken or missing. Coat washers with insulation compound per MIL-S-8660, NSN 6850-00-880-7616.

c. Diode.

(1) Remove four screws holding transistor and circuit board mounting plate, and move plate to one side.

(2) Place negative ohmmeter probe to the top side of diode CR3 (see fig. 2-19).

(3) Place positive probe to the bottom side of CR3. Meter should indicate low resistance.

(4) Reverse probes. Meter should indicate high resistance.

(5) If other readings are obtained replace diode CR3 (MR1122), NSN 5961-00-103-1519 (see fig. 2-19).

d. Relay.

(1) Place ohmmeter probes across relay coil terminals (see fig. 2-20). Meter should read approximately 60 ohms.

(2) Place ohmmeter probes across contactor terminals (see fig. 2-20). Meter should read infinity (open circuit).

(3) If other readings are obtained, replace relay, Vap-Air part number 27124377, NSN 2920-00-735-9542.

(4) Reinstall transistor and circuit board mounting plate.

e. Detailed Circuit Checks.

(1) Table 2-8 contains "power off" resistance checks of the circuit (see fig. 2-22 for test points).

(2) Table 2-9 contains "power on" voltage checks of the circuit (see fig. 2-22 for test points).

f. Functional Checks. Check the performance of the regulator on the test stand and make final voltage adjustments. Voltage output should read 28 volts. If the regulator does not function properly, perform the following:

(1) Check wires and connections.

(2) Replace circuit board, Vap-Air part number 27534930.

(3) Perform bench test procedures.

NOTE

After final repair, check regulator on the test stand.

If the regulator still does not function correctly it will be necessary, if local skills permit, to test each component. All the parts should be checked with an ohmmeter and the capacitors checked with a capacitance meter. The circuit board traces should be checked with an ohmmeter to make sure that there are no cracked traces. Traces with hairline cracks will show good at lower temperatures and will tend to show open circuit at higher temperatures. If the board seems good at room temperature, but the regulator still fails, this could be the cause.

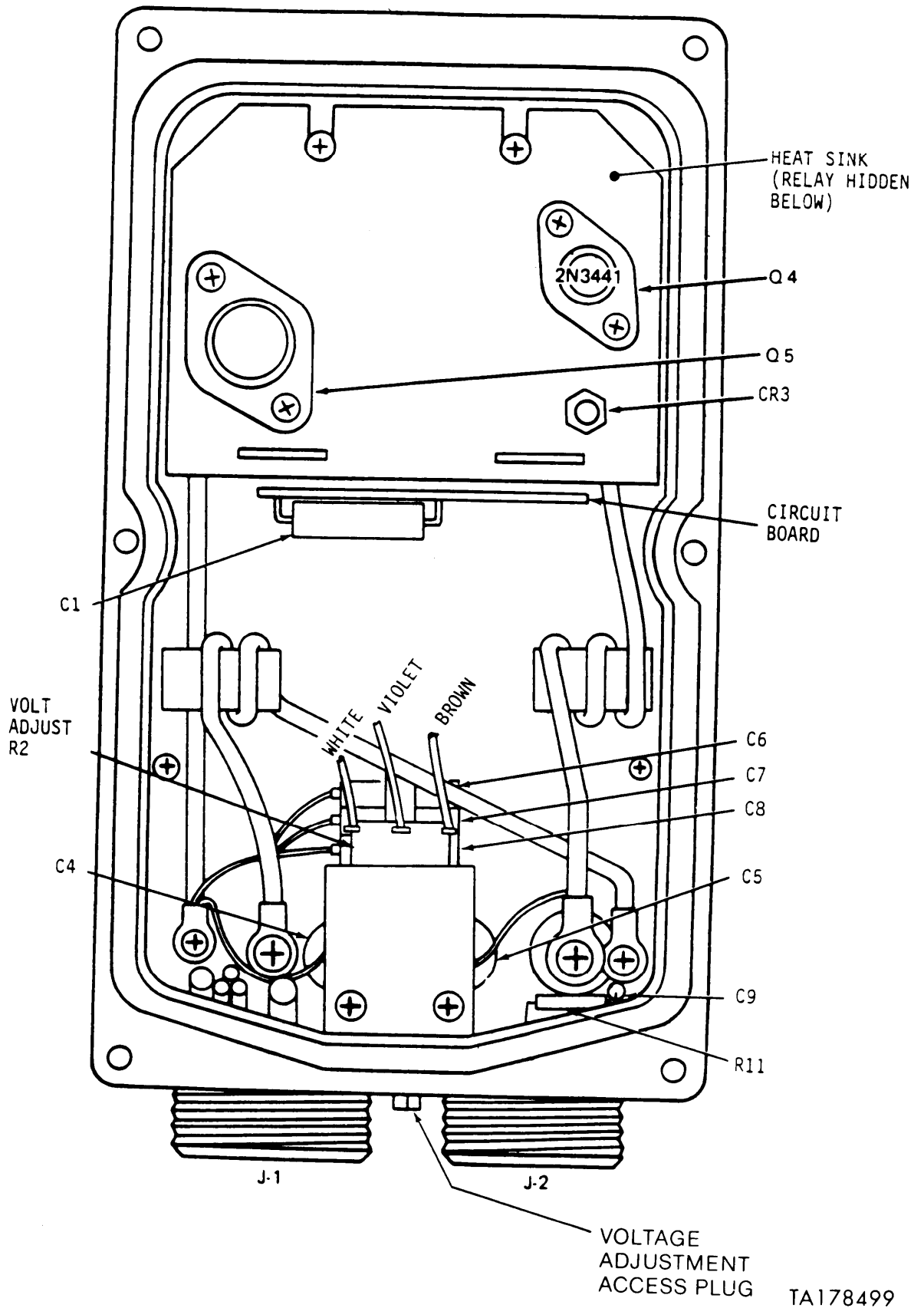

Figure 2-17. Vap-Air model 26440001-05.

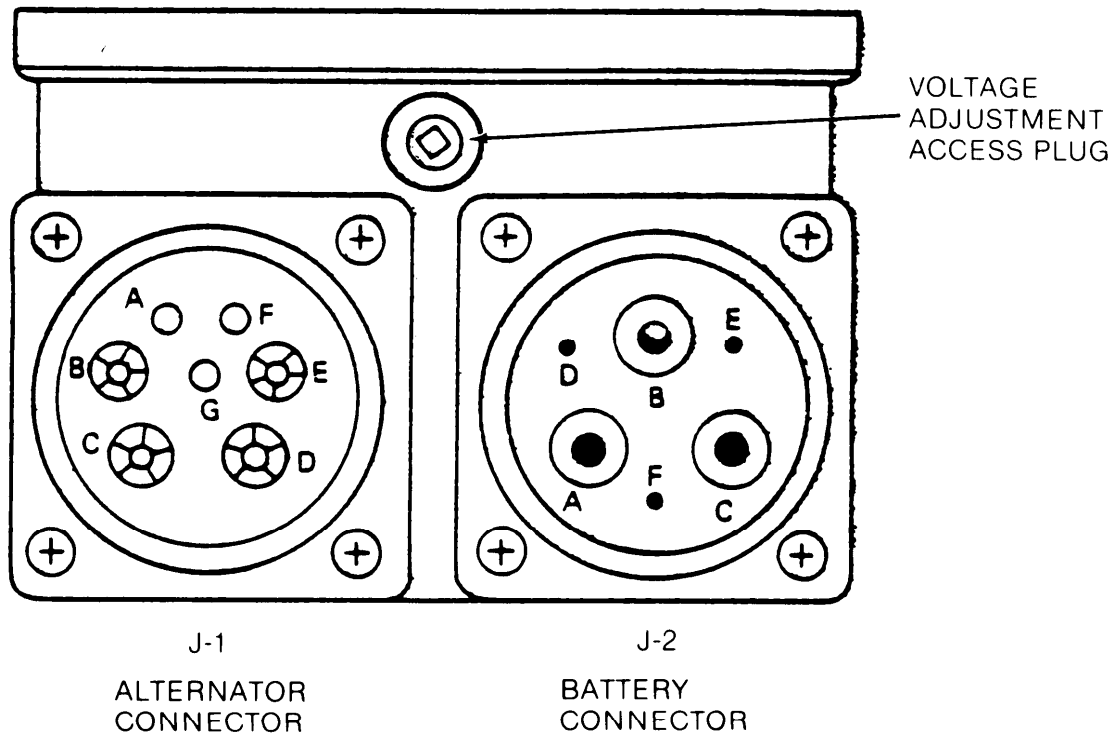
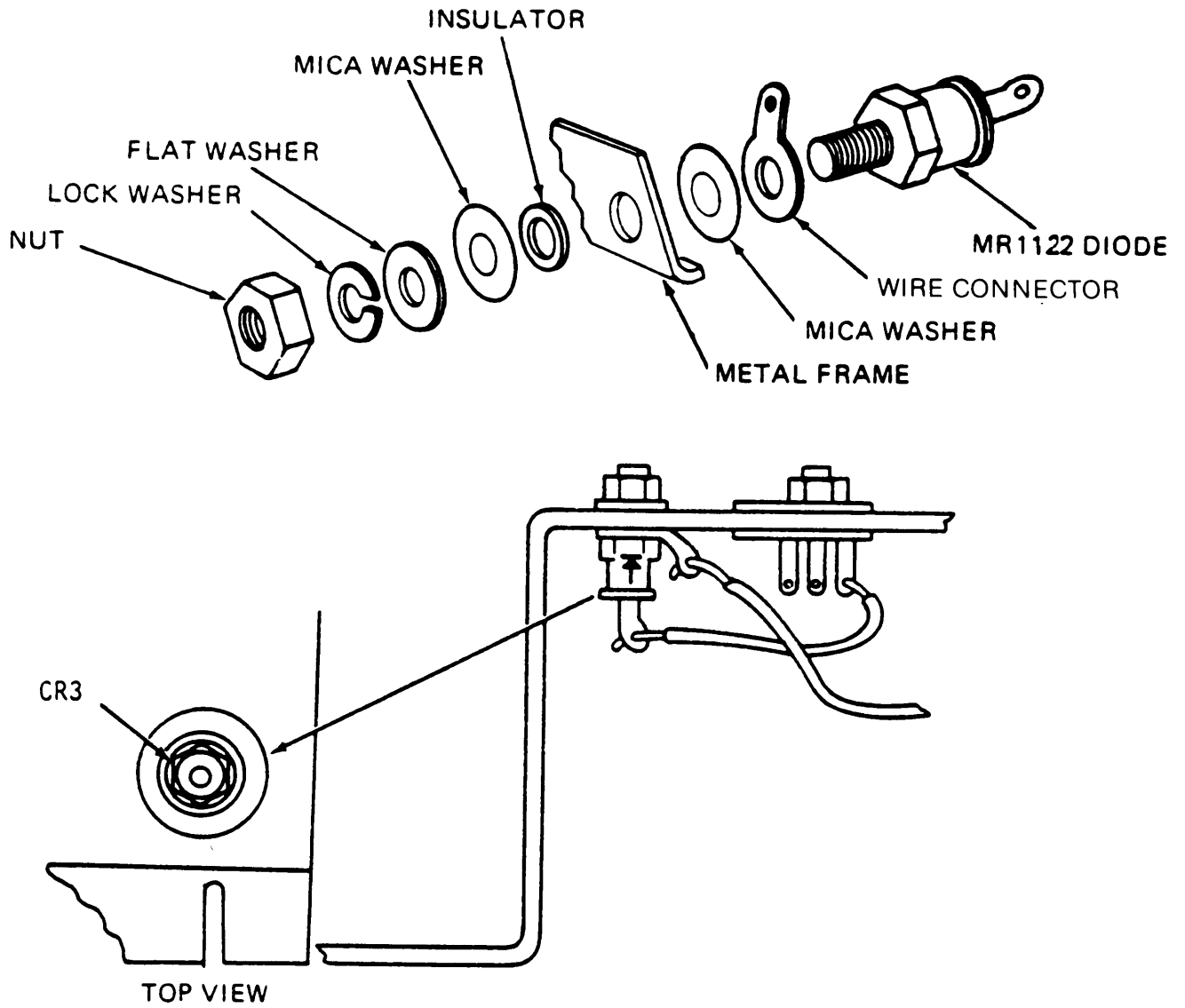
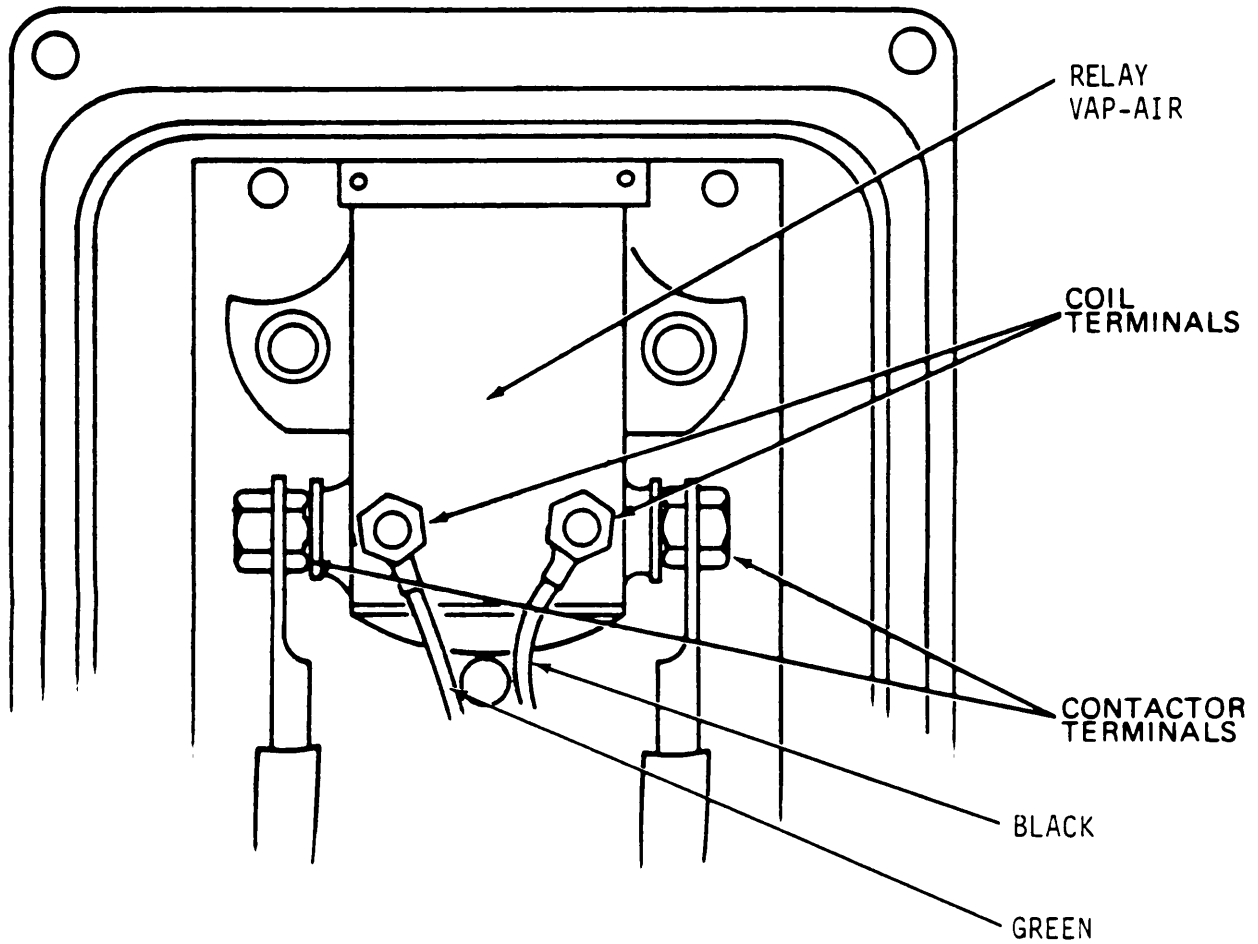

Figure 2-18. End view-model 05.



TA178501

Figure 2-19. Diode mounting—model 05.



TA178502

Figure 2-20. Relay location—model 05.

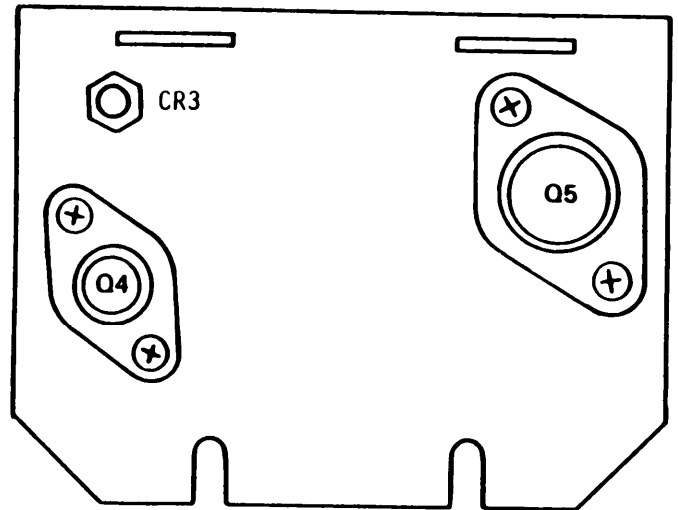
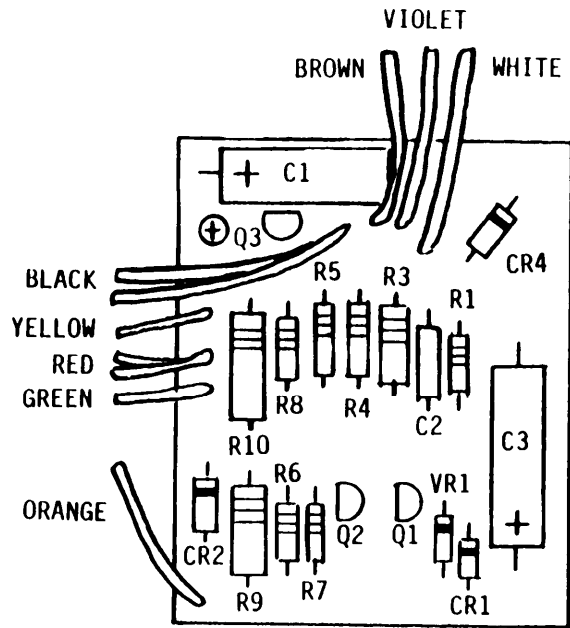

LEGEND

| | | | |
|------------|---------------------|--------------|-------------|
| Q1 2N2222A | R1 13.2K ohms, 1/2W | C1 8.2 MFD | CR1 1N2482 |
| Q2 2N3638A | R2 VAR.250 ohms, 2W | C2 2.2 MFD | CR2 1N5402 |
| Q3 2N2222A | R3 62.1K ohms, 1/2W | C3 82 MFD | CR3 MR 1122 |
| Q4 2N3441 | R4 5.1K ohms, 1/2W | C4 8 MFD | CR4 1N5402 |
| Q5 2N3773 | R5 8.2K ohms, 1/2W | C5 8 MFD | VR1 1N756A |
| | R6 4.7K ohms, 1/2W | C6 .47 MFD | |
| | R7 3.3K ohms, 1/4W | C7 .47 MFD | |
| | R8 1K ohms, 1/2W | C8 .47 MFD | |
| | R9 300 ohms, 1W | C9 .0047 MFD | |
| | R10 300 ohms, 1W | | |
| | R11 .39 ohms, 1W | | |

TA178503

Figure 2-21. Circuit board and transistor heat sink-model 05.

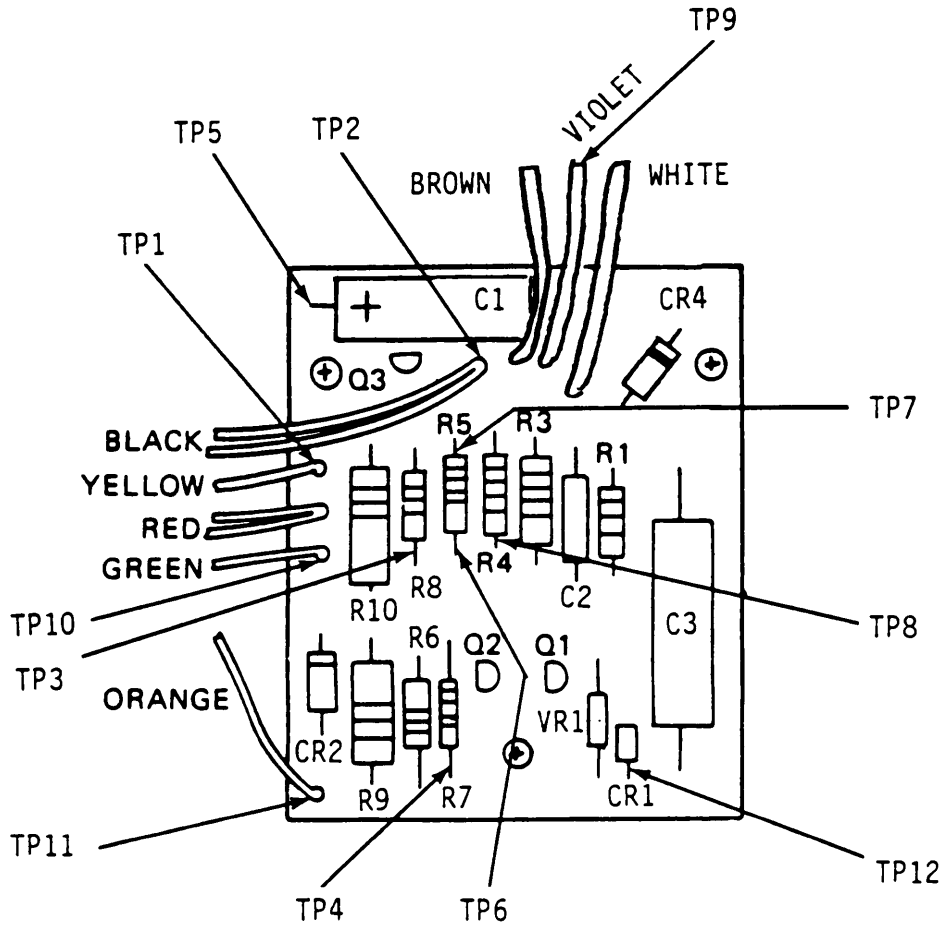

TA178504

Figure 2-22. Test point-model 05.

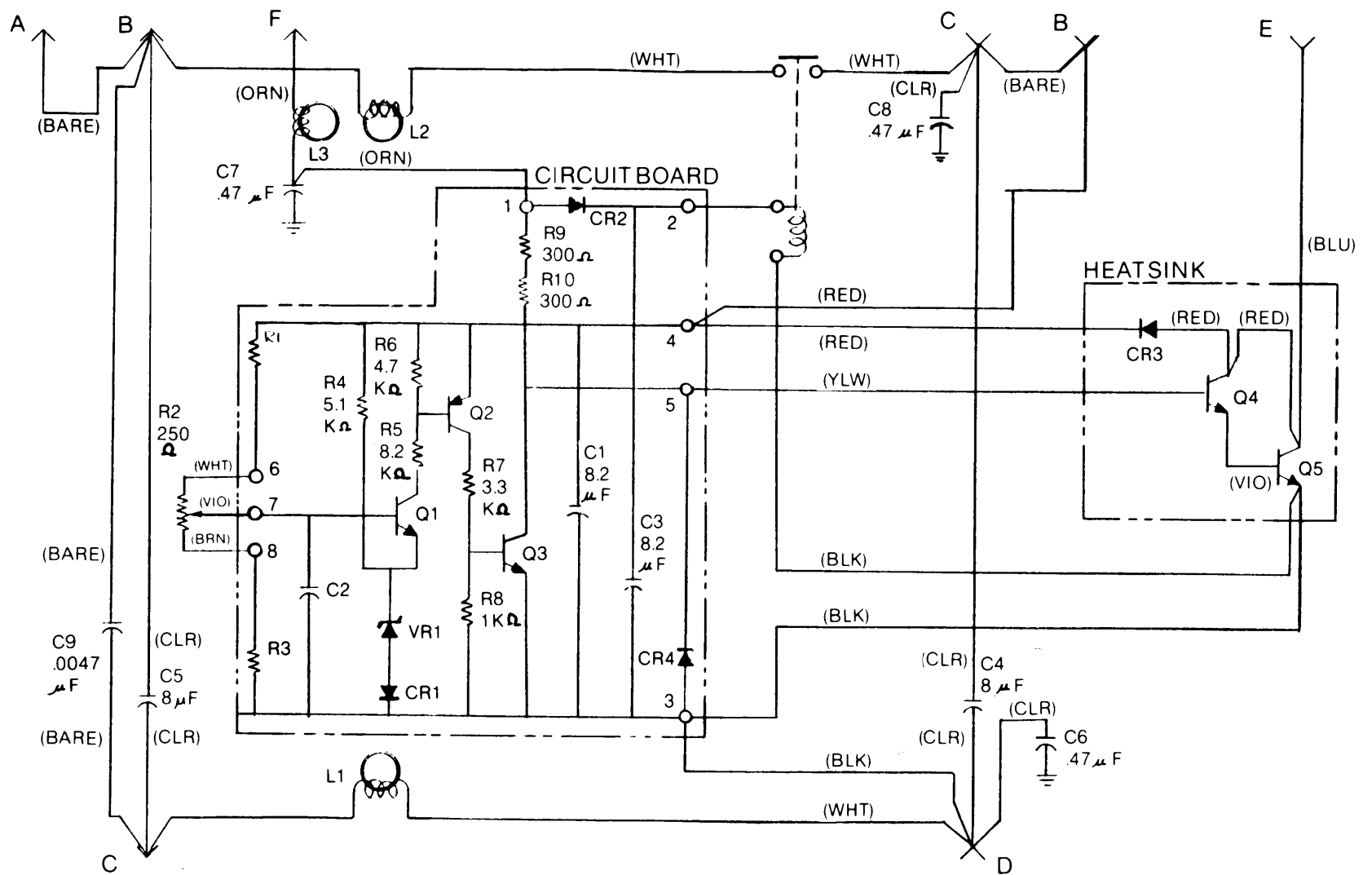

TA178505

Figure 2-23. Schematic diagram—model 05.

Table 2-8. Resistance Checks (Power Off)—Model 05

NOTE

REMOVE TRANSISTORS Q4, Q5 FROM THE CIRCUIT AND ADJUST R2 FULLY CLOCKWISE BEFORE MAKING THESE CHECKS.

| Red for TS352 Negative | Black for TS352 Positive | Resistance (OHMS) | Resistance Scale (TS352 Meter) | Component | NSN |
|--|--|--|--|--|--|
| TP1 TP2 TP1 TP3 TP2 TP3 | TP2 TP1 TP3 TP1 TP3 TP2 | 250-500 750-1500 130-400 1500-5000 150-400 700-1500 | R x 10 | TRANSISTOR Q3 2N2222A | 5961-00-951-8757 |
| <i>Note: See also test for CR4, at end of table3-8</i> | | | | | |
| TP5 TP4 TP6 TP5 TP6 TP4 | TP4 TP5 TP5 TP6 TP4 TP6 | 1000-3500 3000-7000 150-300 2000-5000 150-300 7500-12,000 | R x 10 R x 100 | TRANSISTOR Q2 2N3638A | 5961-00-912-9008 |
| TP7 TP8 TP8 TP9 TP7 TP9 TP10 TP11 | TP8 TP7 TP9 TP8 TP9 TP7 TP11 TP10 | 3000-5000 10,000-20,000 1500-2500 5000-7000 1500-2500 10,000-20,000 15-25 OVER 1000 | R x 100 R x 1 | TRANSISTOR Q1 2N2222A DIODE CR2 1N5402 | 5961-00-951-8757 5961-00-761-4631 |
| TP2 TP12 | TP12 TP2 | 15-25 OVER 1000 | R x 1 | DIODE CR1 1N2482 | 5961-00-833-9050 |
| J1-PIN B J1-PIN E | J1-PIN E J1-PIN B | 5000-15,000 25,000-50,000 | R x 100 | DIODE CR3 MR1122 | 5961-00-103-1519 |
| TP1 TP2 | TP2 TP1 | MORE THAN 200 LESS THAN 50 | R x 1 | DIODE CR4 1N5402 SUBSTITUTES 1N4141 OR 1N4721 1N4721 | 5961-00-761-4631 5961-00-938-7649 5961-00-450-0922 5961-00-929-4975 |

Table 2-9. Voltage Checks (Power On)—Model 05

NOTE

REPLACE TRANSISTORS Q4, Q5 AND ADJUST R2 FULLY COUNTERCLOCKWISE BEFORE MAKING THESE CHECKS.

| | | | | | |
|------|----------|------|------|--------------|------------------|
| TP1 | J1-PIN D | 1.2 | 20.0 | | |
| TP2 | " " | 0.0 | " | DIODE VR1 | |
| TP3 | " " | 0.0 | " | 1N756A | 5961-00-068-2001 |
| TP4 | " " | 0.0 | " | JAN 1N756A | 5961-00-845-6458 |
| TP5 | " " | 20.0 | " | JANTX 1N756A | 5961-00-105-5734 |
| TP6 | " " | 20.0 | " | | |
| TP7 | " " | 20.0 | " | 1N959A | 5961-00-400-1992 |
| TP8 | " " | 8.2 | " | | |
| TP9 | " " | 8.0 | " | | |
| TP10 | " " | 19.0 | " | | |
| TP11 | " " | 20.0 | " | | |
| TP12 | " " | .6 | " | | |
| TP1 | " " | .05 | 30.0 | | |
| TP2 | " " | 0.0 | " | | |
| TP3 | " " | .8 | " | | |

Table 2-9. Voltage Checks (Power On)—Model 05—continued

| Red for TS352 Positive | Black for TS352 Negative | Voltage* (Volts) | Regulator Applied Voltage | Component | NSN |
|---------------------------|-----------------------------|---------------------|------------------------------|---------------------|------------------|
| TP4 | J1-PIN D | 30.0 | " | DIODE CR1 1N2482 | 5961-00-833-9050 |
| TP5 | " " | 30.0 | " | | |
| TP6 | " " | 29.5 | " | | |
| TP7 | " " | 8.5 | " | | |
| TP8 | " " | 8.4 | " | | |
| TP9 | " " | 9.2 | " | | |
| TP10 | J1-PIN D | 29.0 | 30.0 | | |
| TP11 | " " | 30.0 | " | | |
| TP12 | " " | .65 | " | | |

*Values may vary $\pm 5\%$

Table 2-10. Substitutes for Transistor Q5—Model 05

| P/N | NSN |
|--------------|------------------|
| 2N3773 | 5961-00-327-8280 |
| 2N3773 | 5961-00-929-5014 |
| JAN 2N3771 | 5961-00-431-7863 |
| JANTX 2N3771 | 5961-00-758-5816 |
| 2N3772 | 5961-00-438-2156 |
| 2N3772 | 5961-00-854-6759 |
| JAN 2N3772 | 5961-00-403-2566 |
| JANTX 2N3772 | 5961-00-760-1302 |
| 2N5038 | 5961-00-935-6479 |
| JAN 2N5038 | 5961-00-858-8960 |
| JANTX 2N5038 | 5961-00-359-5752 |
| 2N5039 | 5961-00-215-5999 |
| JAN 2N5039 | 5961-00-262-0729 |
| JANTX 2N5039 | 5961-01-033-0822 |
| 2N5671 | 5961-00-481-4205 |
| JAN 2N5671 | 5961-01-019-6400 |
| 2N5672 | 5961-00-523-9171 |
| 2N5679 | 5961-01-003-0584 |
| JANTX 2N5672 | 5961-01-017-0990 |
| 2N6258 | 5961-00-255-9986 |

CHAPTER 3

LEECE-NEVILLE MODELS

Section I. INTRODUCTION

3-1. Introduction. Four models were produced by Leece-Neville, a division of Sheller Globe Corporation.

Code Ident 35510 (FSCM)
 Sheller Globe Corp.
 Leece-Neville Cleveland Div.
 1374 E. 51st St.
 Cleveland, OH 44103
TELEPHONE AC 216 431-0740

The Leece-Neville part numbers for each model are:

R0015027RA
 R0015027RB
 R0015027RC
 R0015027RD

3-2. General Inspection. This chapter applies to all Leece-Neville models.

a. Regulator Box Assembly (external). Check for missing or stripped cover, connector and mount retainer screws, and voltage adjustment access plug. Check connectors for signs of arcing, bent or pushed in pins, broken connectors and thread damage.

Correct deficiencies by utilization of serviceable components from unrepairables or requisitioning components from the manufacturer.

(1) The pin receptacle (J2) is P/N 7064429 FSCM 19207 or MS3102A28-22P FSCM 96906 per MIL-C-5015.

(2) The socket receptacle (J1) is P/N 7064706 FSCM 19207, an ordnance number for which there is no equivalent NSN number. An

assembly is available as an ordnance part from Bendix.

Code Ident 77820 (FSCM)
 Bendix Corp.
 The Electrical Components Div.
 Sherman Ave.
 Sidney, NY 13838

It should be ordered as part number 60-42228-10S; it will arrive as a complete assembly with the shell marked 8701337.

b. Regulator Box Assembly (Internal). If water leakage or corrosion is detected, it is possible that extensive damage has been done and the regulator cannot be easily repaired. Components should be performance tested and retained if acceptable. Check for disconnected or burnt wires, missing components and replace/repair as necessary. Carefully remove the transistor mounting plate, noting the position of the screws, washers and rubber insulators. Visually inspect the circuit board for burnt components. Replace the circuit board through cannibalization if burnt components are found. Carefully reinstall the transistor mounting plate.

c. Regulator Verification Check. After performing the above inspection, if the regulator appears to be in good condition, check its performance on a test stand. If the regulator fails this check, proceed to the following component tests.

3-3. Bench Testing. Figures 3-1 and 3-2 show the method for testing NPN transistors. These figures apply to all models in this chapter.

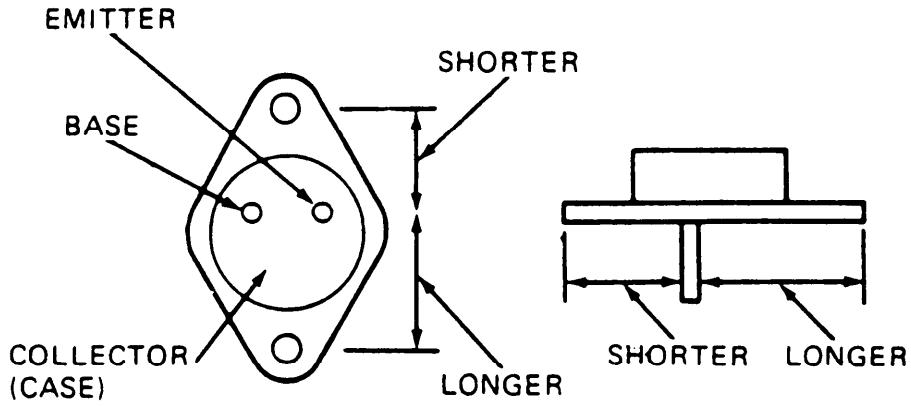

TA178506

Figure 3-1. NPN transistor (Leece-Neville).

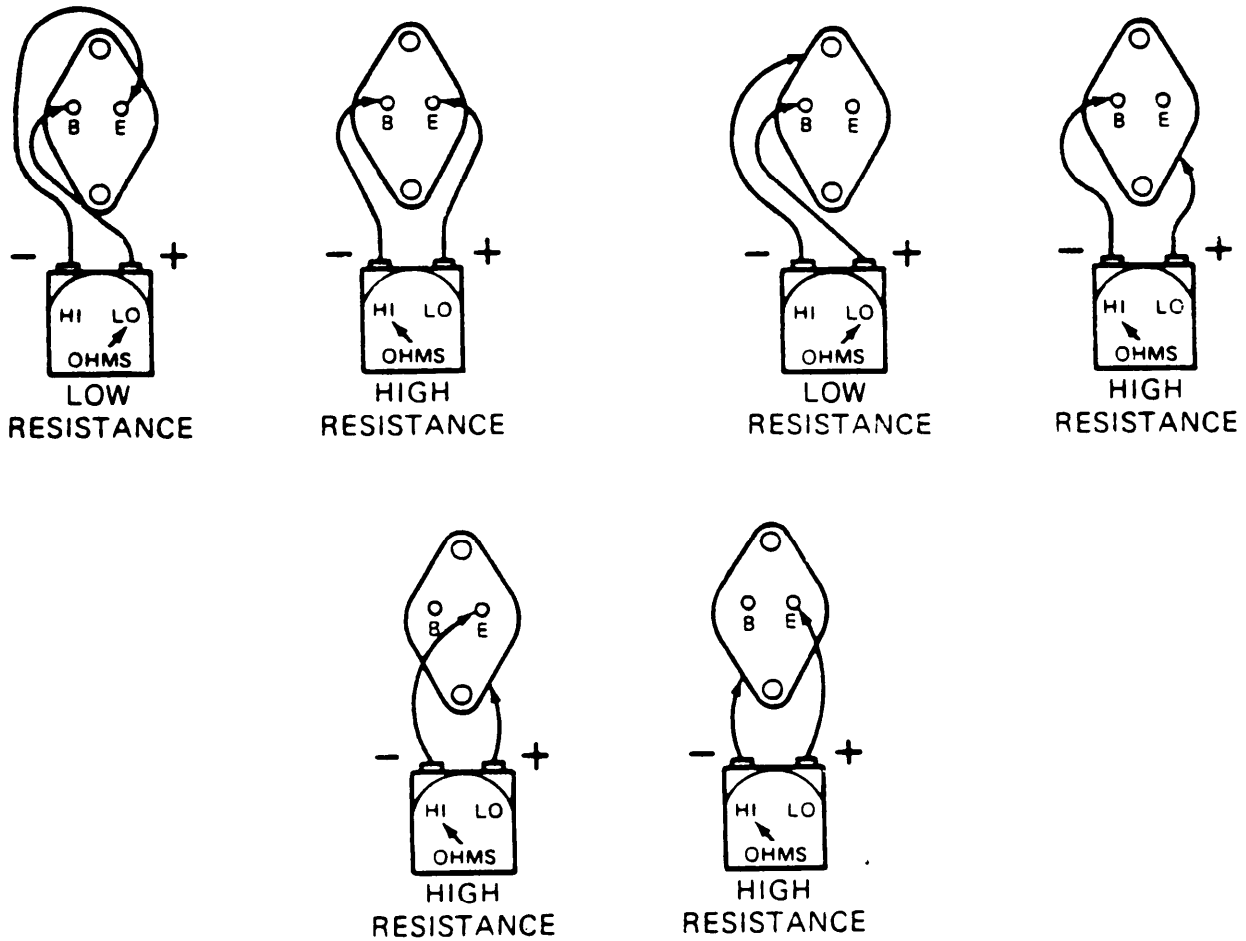

TA178507

Figure 3-2. Transistor resistance checks (Leece-Neville).

Section II. LEECE-NEVILLE MODEL R0015027RA

3-4. General. Figure 3-3 is a plan view of the regulator with the cover removed, showing the remaining test points. There are 10 total test points. Figure 3-5 is an electrical schematic diagram of the regulator circuit.

3-5. Checkout and Repair.

a. Diode D2 and Relay (see fig. 3-3 and 3-5) (voltage off).

(1) Place positive probe of ohmmeter to pin F of connector J2 and negative probe on TP1. Meter should read 0 ohms.

(2) Place positive probe on TP1 and negative probe on TP2. Meter should read low ohms (hundreds).

(3) Reverse probes in (2) above. Meter should read high ohms (thousands).

(4) If other readings are obtained in (2) or (3) above, replace diode D1.

(5) Place positive probe on TP2 and negative probe on Pin C of connector J2. Meter should read approximately 55 ohms.

(6) If another reading is obtained, remove and replace both the relay and diode D2.

b. Resistor R1. Replace ohmmeter probe across resistor R1 (see figs. 3-3 and 3-5). Meter should read approximately 0.4 ohms.

c. Voltage Adjustment Rheostat (R15).

(1) Remove voltage adjustment access screw from the cover of regulator.

(2) Place ohmmeter probes to terminals of the rheostat (see figs. 3-4 and 3-5).

(3) Rotate rheostat fully clockwise; reading should be approximately 45 ohms.

(4) Rotate rheostat fully counterclockwise; reading should be less than 5 ohms.

(5) If other readings are obtained, replace the rheostat, NSN 5905-00-581-1405.

d. Power Resistor R2. Place ohmmeter probes across power resistor R2 (see figs. 3-4 and 3-5). Meter should read approximately 30 ohms.

e. Detailed Circuit Checks.

(1) Table 3-1 contains "power off" resistance checks of the circuit (see figs. 3-3 and 3-4 for test points).

(2) Table 3-2 contains "power on" voltage checks of the circuit (see figs. 3-3 and 3-4 for test points).

f. Functional Check. Check the performance of the regulator on the test stand and make final voltage adjustments. Voltage output should read 28 volts. If the regulator does not function properly, perform the following:

(1) Check wires and connections.

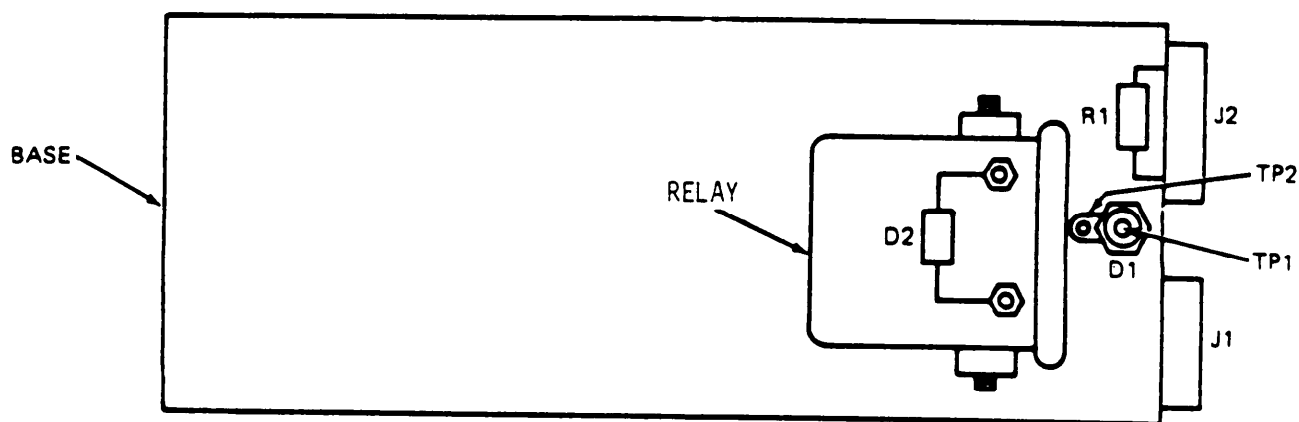

LEGEND

R1 .4 OHMS, 1W
D1 1N1342A
D2 1N4820

TP1 TEST POINT =1
TP2 TEST POINT =2

TA178508

Figure 3-3. Top-view (Leece-Neville)-model R0015027RA.

- (2) Replace cover assembly.
- (3) Perform bench test procedures.

NOTE

After final repair, check regulator on the test stand.

If the regulator still does not function correctly

it will be necessary, if local skills permit, to test each component. All the parts should be checked with an ohmmeter to make sure that there are no cracked traces. Traces with hairline cracks will show good at lower temperatures and will tend to show open circuit at higher temperatures. If the board seems good at room temperature, but the regulator still fails, this could be the cause.

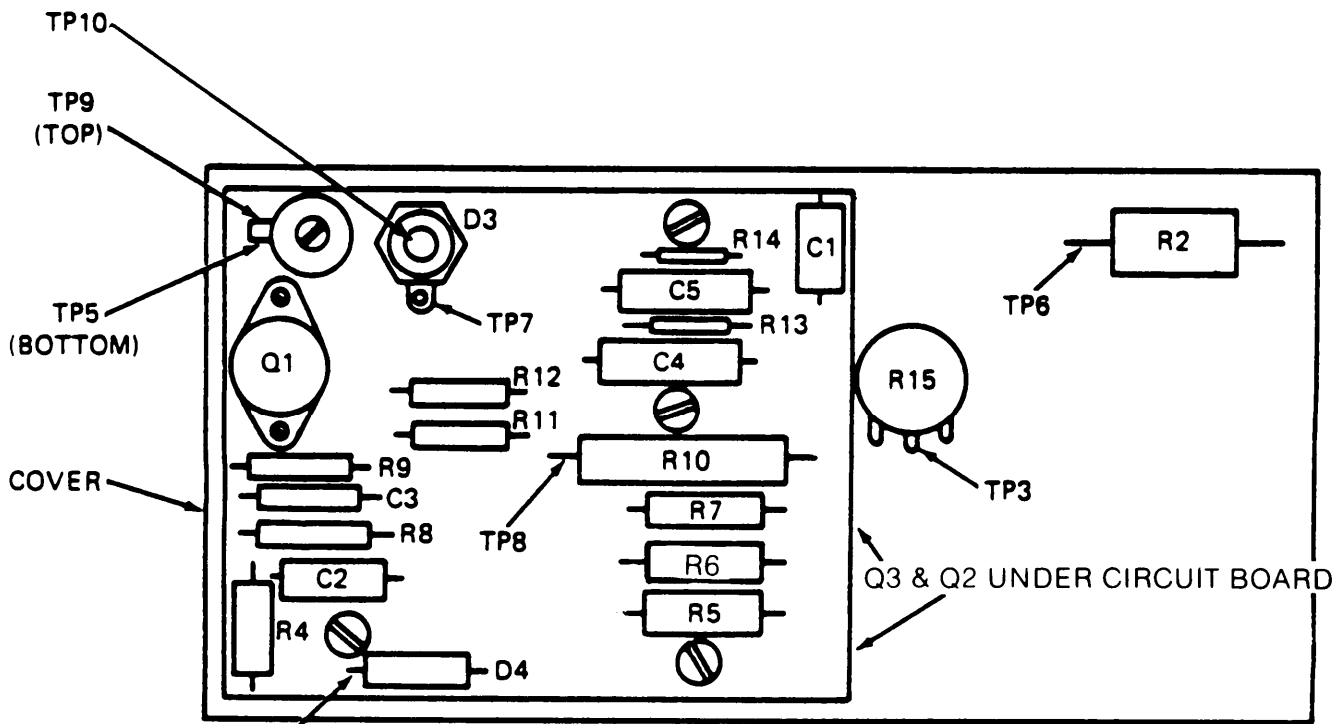

LEGEND

- R1 .4 OHMS, 1W
- R2 30 OHMS, 8W
- R3 .05 OHMS, 8W
- R4 150 OHMS, 1/2W
- R5 50 OHMS, 1/2W
- R6 50 OHMS, 1/2W
- R7 120 OHMS, 1/2W
- R8 220 OHMS, 1/2W
- R9 4 OHMS, 2W
- R10 500 OHMS, 3W
- R11 4000-6000 OHMS @ 80°F*
- D3 1N1341AR
- D4 1N3022A

*(NOTE: AS TEMPERATURE INCREASES RESISTANCE DECREASES.)

- R12 2.5K OHMS, 1/2W
- R13 820 OHMS, 1/4W
- R14 100 OHMS, 1/4W
- R15 500 OHMS VAR, 2W
- C1 .22 MFD, 100 VDC
- C2 47 MFD, 35 VDC
- C3 .22 MFD, 100 VDC
- C4 22 MFD, 100 VDC
- C5 .47 MFD, 100 VDC
- TP3 TEST POINT #3 thru thru
- TP10 TEST POINT #10

TA178509

Figure 3-4. Circuit board-model R0015027RA.

J-1
ALTERNATOR

J-2 BATTERY

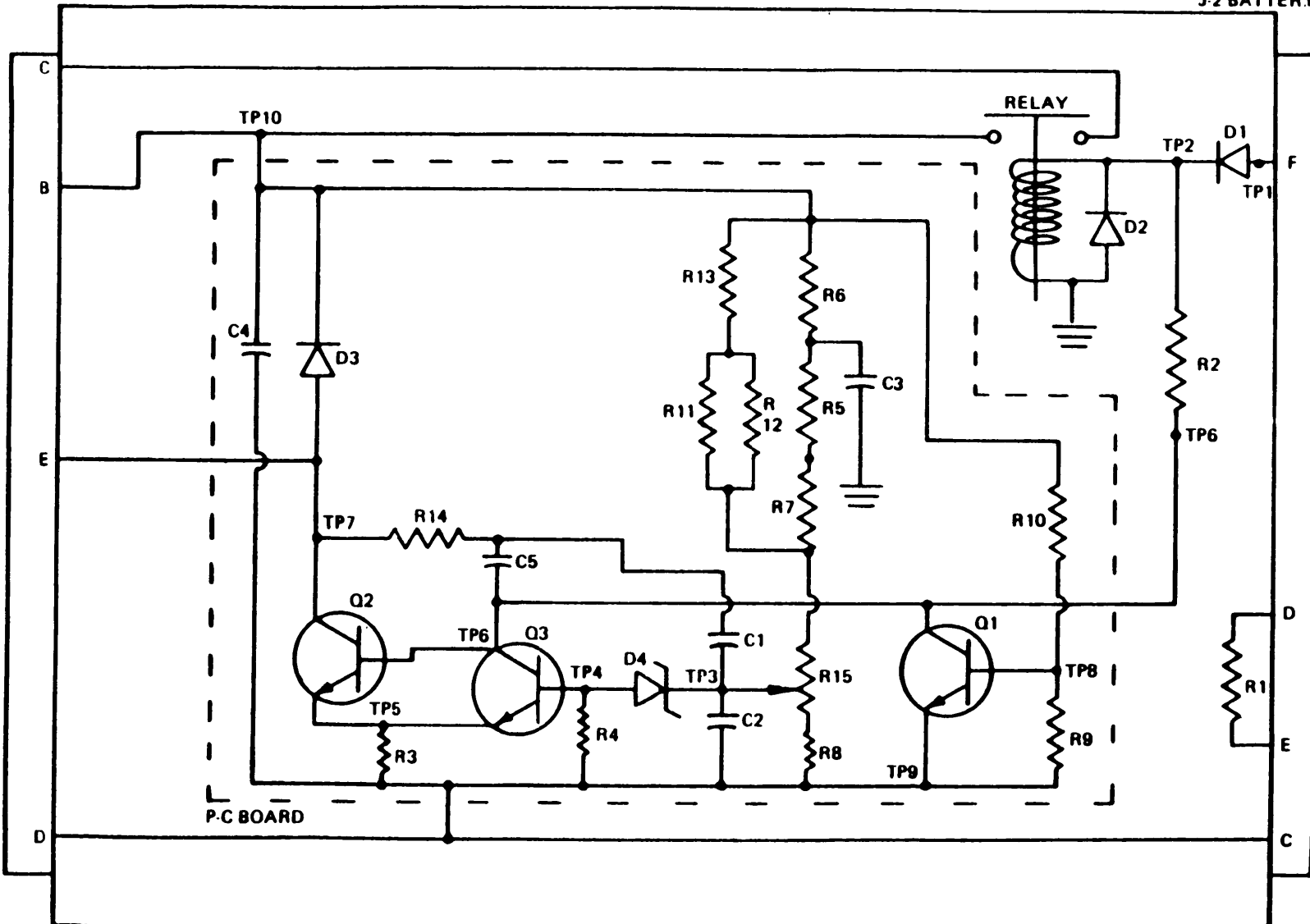

LEECE-NEVILLE REG.
5027-RA

TA178510

Figure 3-5. Schematic diagram—model R0015027RA.

Table S-1. Resistance Checks (Power Off)—Model 5027RA

NOTE**ADJUST (R15) FULLY CLOCKWISE BEFORE MAKING THESE CHECKS.**

| Red for TS352 Negative | Black for TS352 Positive | Resistance (OHMS) | Resistance Scale (TS352 Meter) | Component | NSN |
|--|--|--|-----------------------------------|--------------------------------------|--------------------------------------|
| TP1 TP2 | TP2 TP1 | OVER 500 15-30 | R x 1 | DIODE D1 1N1342A | 5961-00-054-9138 |
| TP2 TP9 | TP9 TP2 | 15-25 30-50 | R x 1 | RELAY 71136 DIODE D2 1N4820 | 5945-00-270-1209 5961-00-624-4929 |
| TP7 TP10 | TP10 TP7 | 15-30 300-700 | R x 1 | DIODE D3 1N3022B | 5961-01-038-0809 |
| TP3 TP4 | TP4 TP3 | 15-30 200-500 | R x 1 | DIODE D3 1N3022B | 5961-01-038-0809 |
| TP5 TP4 TP4 TP6 TP6 TP5 | TP4 TP5 TP6 TP4 TP5 TP6 | 15-25 100-200 150-500 15-25 10-25 10-25 | R x 1 | TRANSISTOR Q3 26316033-20 | 5961-00-133-0396 |
| TP6 TP7 TP5 TP7 TP5 TP6 | TP7 TP6 TP7 TP5 TP6 TP5 | 300-700 10-25 300-700 15-30 10-25 10-25 | R x 1 | TRANSISTOR Q3 2N3447 | 5961-00-899-9899 |
| TP6 TP7 TP5 TP7 TP5 TP6 | TP7 TP6 TP7 TP5 TP6 TP5 | 300-700 10-25 300-700 15-30 10-25 10-25 | R x 1 | TRANSISTOR Q2 2N3447 | 5961-00-899-9899 |
| TP6 TP8 TP8 TP9 TP9 TP6 | TP8 TP6 TP9 TP8 TP6 TP9 | 10-25 20-30 4 4 10-25 10-25 | R x 1 | TRANSISTOR Q1 2N3447 | 5961-00-899-9899 |

Table 3-2. Voltage Checks (Power On)—Model 5027RA

NOTE**ADJUST R15 FULLY CLOCKWISE BEFORE MAKING THESE CHECKS.**

| Red for TS352 Positive | Black for TS352 Negative | Voltage* (Volts) | Regulator Applied Voltage | Component | NSN |
|---------------------------|-----------------------------|---------------------|------------------------------|---------------------|------------------|
| TP1 | J1-PIN D | 20.0 | 20.0 | DIODE D4 1N3022B | 5961-01-038-0809 |
| TP2 | " " | 19.5 | " | | |
| TP3 | " " | 12.0 | " | | |
| TP4 | " " | BELOW .25 | " | | |
| TP5 | " " | 0.0 | " | | |
| TP6 | " " | .8 | " | | |
| TP7 | " " | .10 | " | | |
| TP8 | " " | .20 | " | | |
| TP9 | " " | 0.0 | " | | |
| TP10 | " " | 20.0 | " | | |

See footnote at end of table.

Table 3-2. Voltage Checks (Power On—Model 5027RA-continued)

| Red for TS352 Positive | Black for TS352 Negative | Voltage* (Volts) | Regulator Applied Voltage | Component | NSN |
|---------------------------|-----------------------------|---------------------|------------------------------|---------------------|------------------|
| TP1 | J1-PIN D | 30.0 | 30.0 | DIODE D4 1N3022B | 5961-01-038-0809 |
| TP2 | " " | 29.5 | " | | |
| TP3 | " " | 13.0 | " | | |
| TP4 | " " | .75 | " | | |
| TP5 | " " | 0.0 | " | | |
| TP6 | " " | .15 | " | | |
| TP7 | " " | 30.0 | " | | |
| TP8 | " " | .25 | " | | |
| TP9 | " " | 0.0 | " | | |
| TP10 | " " | 30.0 | " | | |

*Values may vary $\pm 5\%$

Section III. LEECE-NEVILLE MODEL R0015027RB

3-6. General. Figure 3-6 is an exploded view of the regulator, listing the major subassemblies. Figure 3-7 is a plan view of the box and an underside view of the cover, showing the interconnect wiring.

3-7. Checkout and Repair.

a. Diode and Relay (power disconnected).

(1) Place positive probe of ohmmeter to pin F of connector J2 (see fig. 3-7).

(2) Place negative probe to top connection of diode CR2, (see fig. 3-7). Meter should read 0 ohms.

(3) Place negative probe to TP1. Meter should indicate low resistance.

(4) Reverse probes. Meter should indicate high resistance.

(5) If other readings are obtained, replace diode CR2.

(6) Move negative probe to pin C of connector J1. Meter should read approximately 55 ohms.

(7) If another reading is obtained, replace relay (see fig. 3-7).

b. Power Resistor. Place ohmmeter probes across power resistor R1 (see fig. 3-7). Meter should read approximately 40 ohms.

c. Voltage Adjustment Rheostat.

(1) Remove voltage adjustment access screw from the cover of regulator.

(2) Place ohmmeter probes to terminals of the rheostat (see fig. 3-7).

(3) Rotate rheostat fully clockwise, reading should be approximately 45 ohms.

(4) Rotate rheostat fully counterclockwise, reading should be less than 5 ohms.

(5) If other readings are obtained, replace the rheostat.

d. Transistor and Circuit Board. If no faulty components were detected after performing tests a, b, and c, replace the cover assembly (see fig. 3-7).

NOTE

After final repair, check regulator on the test stand.

If the regulator still does not function correctly it will be necessary, if local skills permit, to test each component. All the parts should be checked with an ohmmeter and the capacitors checked with a capacitance meter. The circuit board traces should be checked with an ohmmeter to make sure there are no cracked traces. Traces with hairline cracks will show good at lower temperatures and will tend to show open circuit at higher temperatures. If the board seems good at room temperature, but the regulator still fails, this could be the cause.

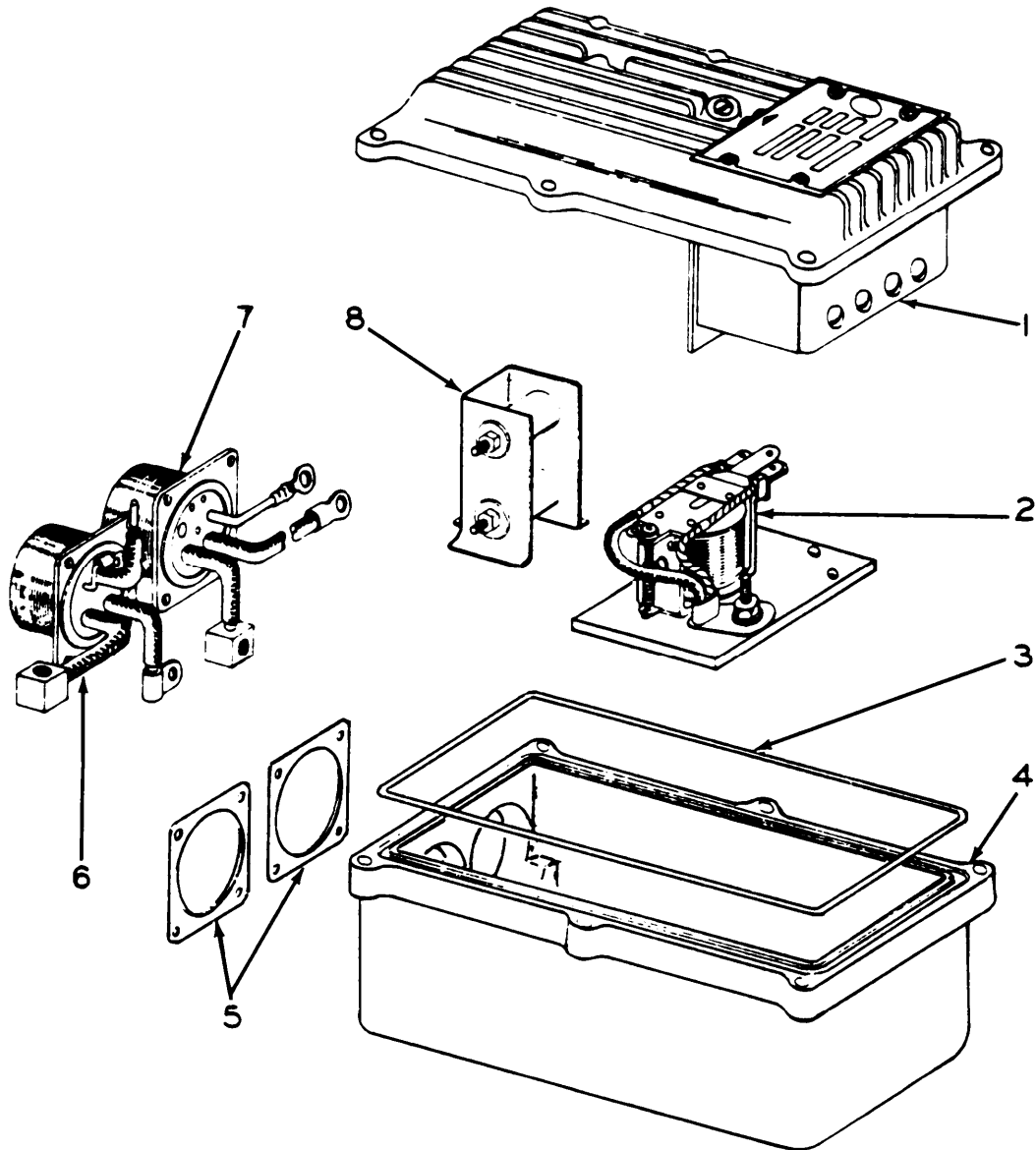

| Ref. No. | Part No. | Qty | Description |
|----------|----------|-----|------------------------------|
| 1 | 71110 | 1 | Cover Assembly, Regulator |
| 2 | 71111 | 1 | Panel & Element Assembly |
| 3 | 36010 | 1 | "O" Ring, Regulator Box |
| 4 | 71106 | 1 | Box & Insert Assembly |
| 5 | 36071 | 2 | Gasket, Receptacle |
| 6 | 71107 | 1 | Connector & Lead Assembly |
| 7 | 71108 | 1 | Connector & Lead Assembly |
| 8 | 71109 | 1 | Capacitor & Bracket Assembly |

TA178511

Figure 3-6. Leece-Neville model 5027RB exploded view.

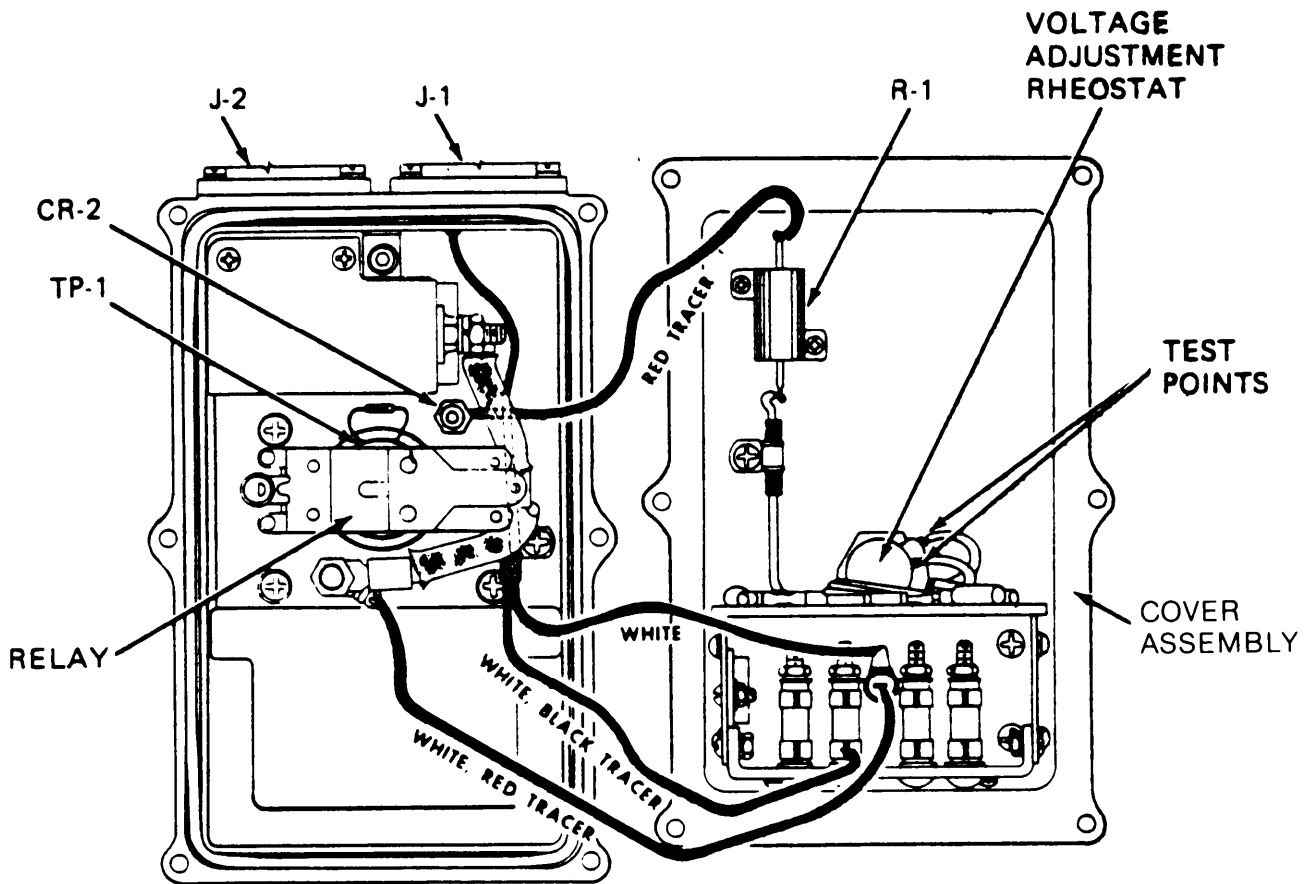

TA178512

Figure 3-7. Open view—model 5027RB.

Section IV. LEECE-NEVILLE MODEL R0015027RC

3-8. General. Figure 3-8 is an exploded view of the regulator, listing the major subassemblies. Figure 3-9 is a plan view of the box subassembly and an underside view of the cover subassembly, showing the interconnect wiring. Figure 3-10 is a plan view of the box and an underside view of the cover showing the components and test points. There are 10 test points. Figure 3-11 is an electrical schematic diagram of the regulator circuit.

3-9. Checkout and Repair.

a. Diode D2 and Relay (see jigs. 3-8 through 3-11) (voltage off).

(1) Place positive probe of ohmmeter to pin F of connector J2 and negative probe on TP1. Meter should read 0 ohms.

(2) Place positive probe on TP1 and negative

probe on TP2. Meter should read low ohms (hundreds).

(3) Reverse probes in (2) above. Meter should read high ohms (thousands).

(4) If other readings are obtained in (2) or (3), replace diode D1.

(5) Place positive probe on TP2 and negative probe on pin C of connector J2. Meter should read approximately 55 ohms.

(6) If another reading is obtained, remove and replace both the relay and diode D2.

b. Resistor R1. Place ohmmeter probes across resistor R1 (see figs. 3-9, 3-10, and 3-11), Meter should read approximately 0.4 ohms.

c. Voltage Adjustment Rheostat.

(1) Remove voltage adjustment access screw from cover of regulator.

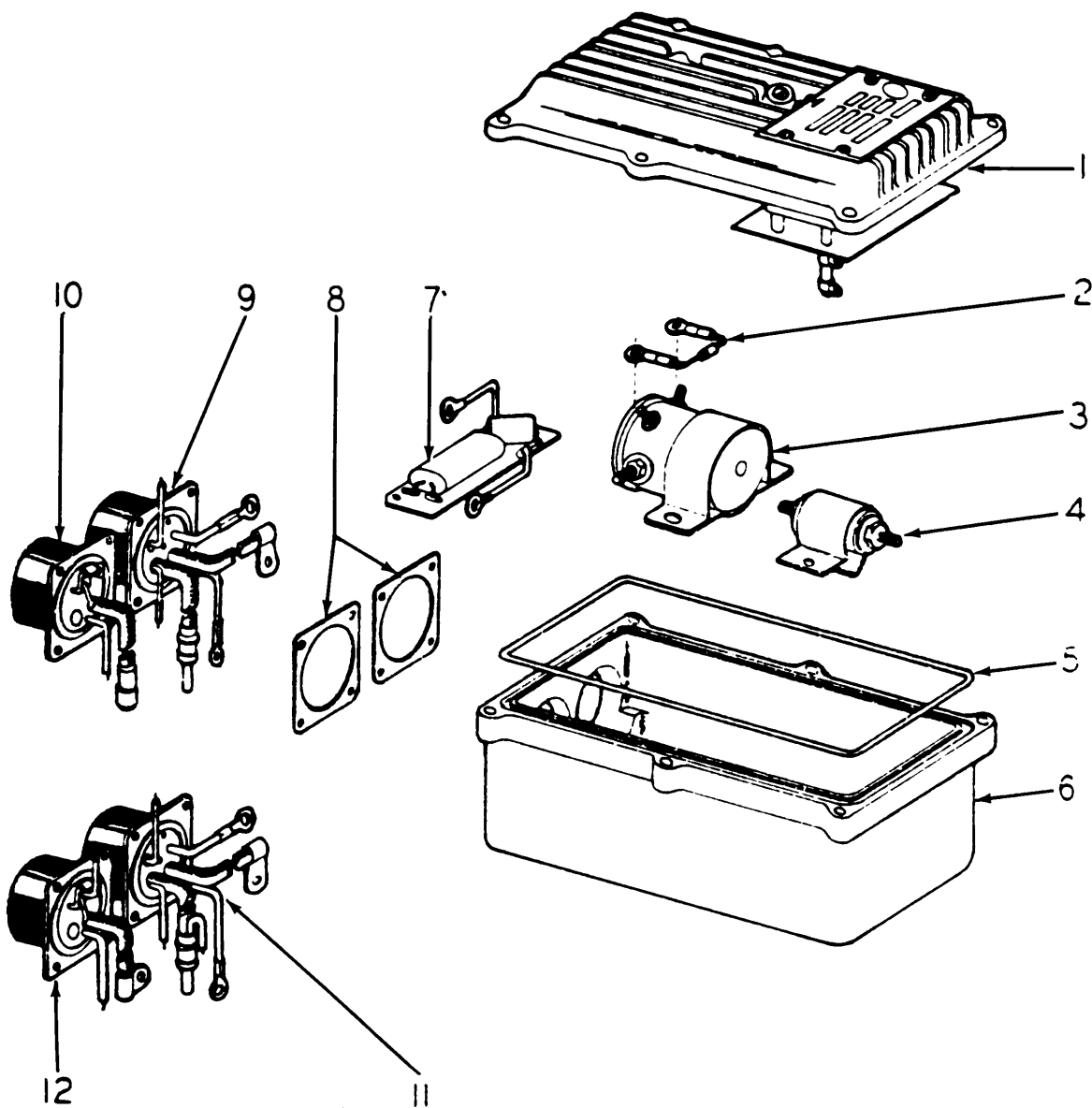

| SERIAL NO. 0 - 25,000 | | | |
|-----------------------|----------|------|------------------------------|
| Ref. No. | Part No. | Qty. | Description |
| 1 | 71131 | 1 | Cover Assembly, Regulator |
| 2 | 71137 | 1 | Diode Assembly |
| 3 | 71136 | 1 | Relay |
| 4 | 71135 | 1 | Capacitor & Bracket Assembly |
| 5 | 36010 | 1 | "O" Ring, Regulator Box |
| 6 | 71132 | 1 | Box & Insert Assembly |
| 8 | 36071 | 2 | Gasket, Receptacle |
| 9 | 71133 | 1 | Connector & Lead Assembly |
| 10 | 71134 | 1 | Connector & Lead Assembly |

| SERIAL NO. 25,000 - UP | | | |
|------------------------|----------|-----|---------------------------|
| Ref. No. | Part No. | Qty | Description |
| 1 | 71131 | 1 | Cover Assembly, Regulator |
| 2 | 71137 | 1 | Diode Assembly |
| 3 | 71136 | 1 | Relay |
| 5 | 36010 | 1 | "O" Ring, Regulator Box |
| 6 | 71146 | 1 | Box & Insert Assembly |
| 7 | 71148 | 1 | Panel Assembly |
| 8 | 36071 | 2 | Gasket, Receptacle |
| 11 | 71147 | 1 | Connector & Lead Assembly |
| 12 | 71145 | 1 | Connector & Lead Assembly |

TA178513

Figure 3-8. Leece-Neville model 5027RC exploded view.

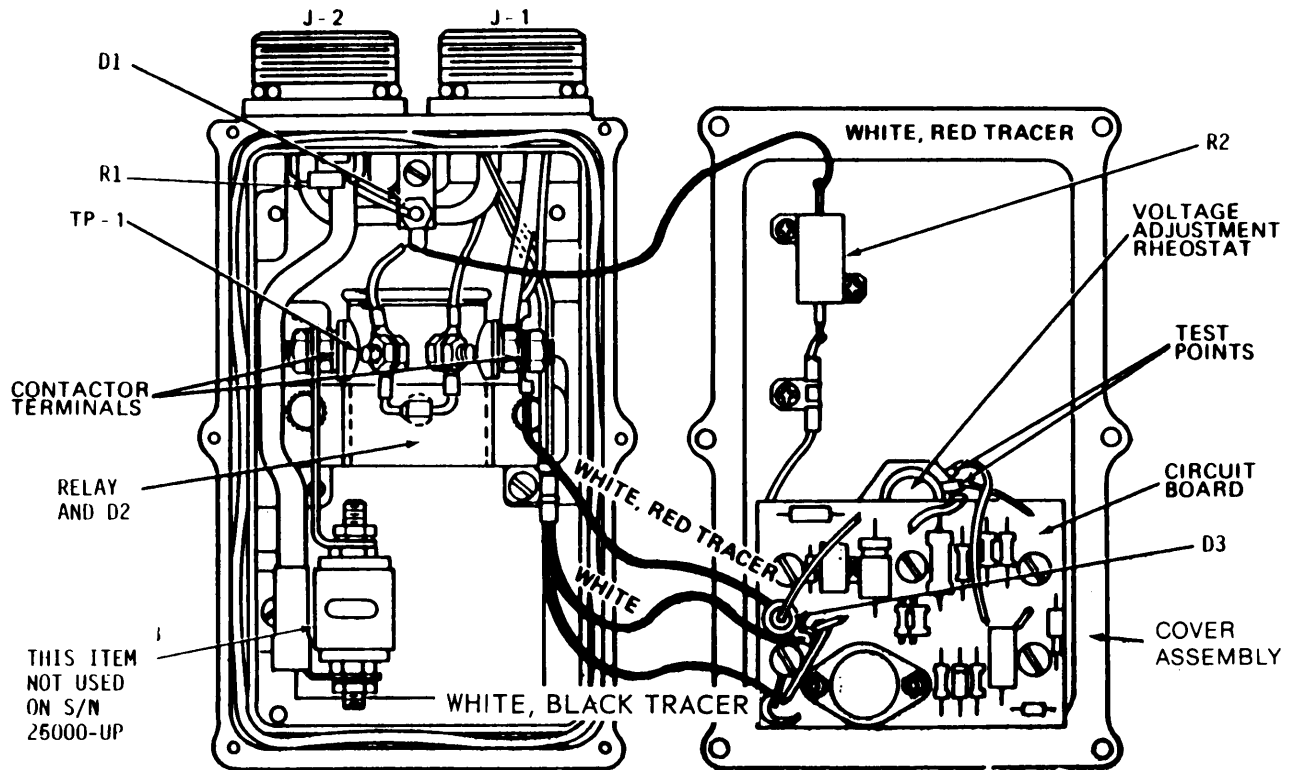

TA178514

Figure 3-9. Open view-mode 5027 RC.

(2) Place ohmmeter probes to the terminals of the rheostat (see figs. 3-9, 3-10, and 3-11).

(3) Rotate rheostat fully clockwise; reading should be approximately 45 ohms.

(4) Rotate rheostat fully counterclockwise, reading should be less than 5 ohms.

(5) If other readings are obtained, replace the rheostat.

d. Power Resistor R2. Place ohmmeter probes across power resistor R2 (see figs. 3-9, 3-10, and 3-11). Meter should read approximately 30 ohms.

e. Detailed Circuit Checks.

(1) Table 3-4 contains "power off" resistance checks of the circuit (see figs. 3-9, 3-10, and 3-11 for test points).

(2) Table 3-4 contains "power on" voltage checks of the circuit (see figs. 3-9, 3-10, and 3-11 for test points).

NOTE

Power transistors on the circuit board and heat sink can be checked as outlined on figures 3-1 and 3-2. However, since they are soldered into the circuit, removal and replacement is more time consuming.

f. Functional Check. Check the performance of the regulator on the test stand and make final voltage adjustments. Voltage output should read 28 volts. If the regulator does not function properly, perform the following:

- (1) Check wires and connections.
- (2) Replace circuit board or cover assembly.
- (3) Perform bench test procedures.

NOTE

After final repair, check regulator on the test stand.

If the regulator still does not function correctly it will be necessary, if local skills permit, to test each component. All the parts should be checked with an ohmmeter and the capacitors checked with a capacitance meter. The circuit board traces should be rechecked with an ohmmeter to make sure that there are no cracked traces. Traces with hair-line cracks will show good at lower temperatures and will tend to show open circuit at higher temperatures. If the board seems good at room temperature, but the regulator still fails, this could be the cause.

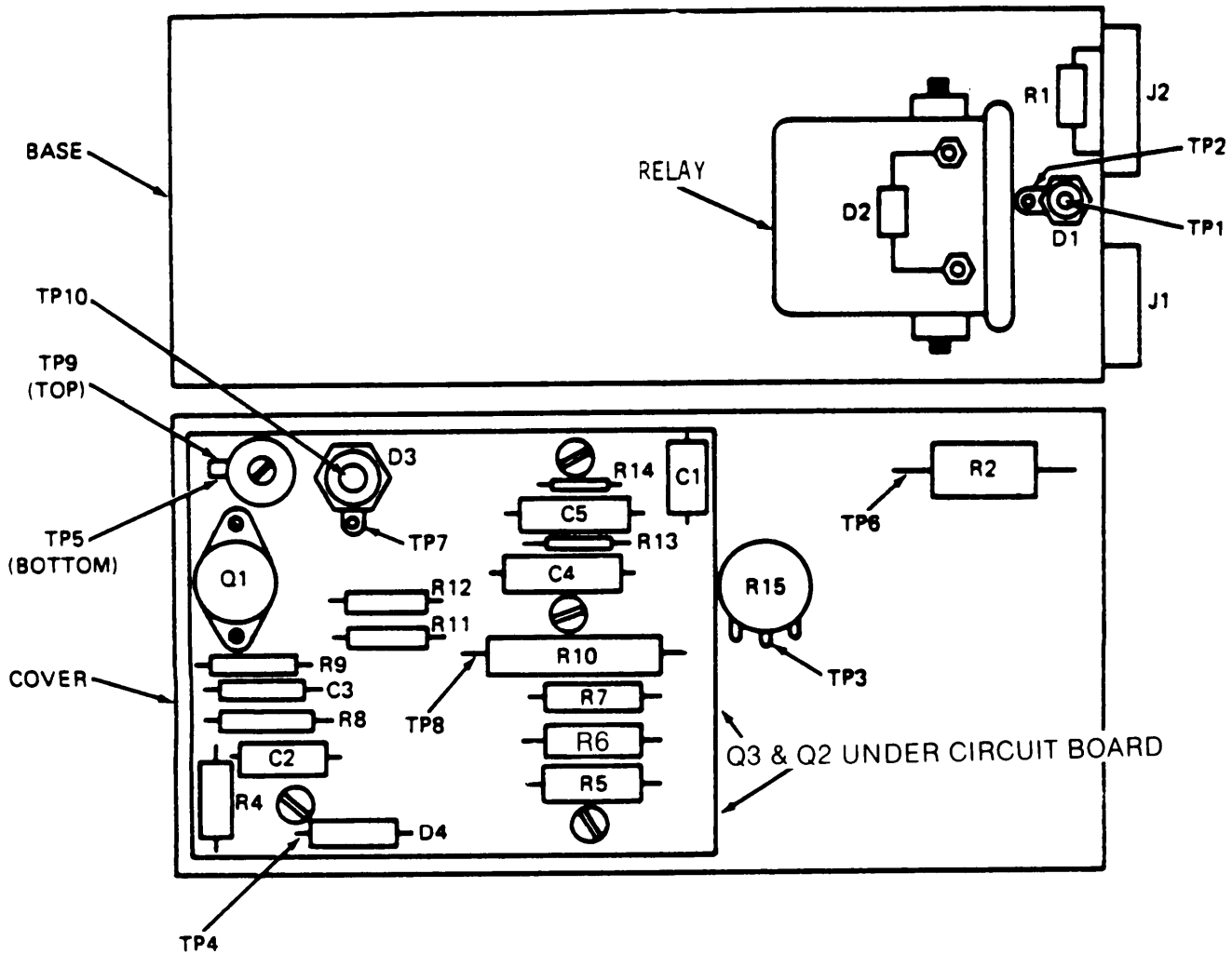

LEGEND

- R1 .4 OHMS, 1W
- R2 30 OHMS, 8W
- R3 .05 OHMS, 8W
- R4 150 OHMS, 1/2W
- R5 50 OHMS, 1/2W
- R6 50 OHMS, 1/2W
- R7 120 OHMS, 1/2W
- R8 220 OHMS, 1/2W
- R9 4 OHMS, 2W
- R10 500 OHMS, 3W
- R11 4000-6000 OHMS @ 80°F

(NOTE: AS TEMPERATURE INCREASES RESISTANCE DECREASES.)

- R12 2.5K OHMS, 1/2W
- R13 820 OHMS, 1/4W
- R14 100 OHMS, 1/4W
- R15 500 OHMS, VAR, 2W
- C1 .22 MFD, 100 VDC
- C2 47 MFD, 35 VDC
- C3 .22 MFD, 100 VDC
- C4 22 MFD, 100 VDC
- C5 .47 MFD, 100 VDC
- TP1 TEST POINT #1 thru thru
- TP10 TEST POINT #10

TA178515

Figure 3-10. Circuit board model 5027RC.

J-1
ALTERNATOR

J 2 BATTERY

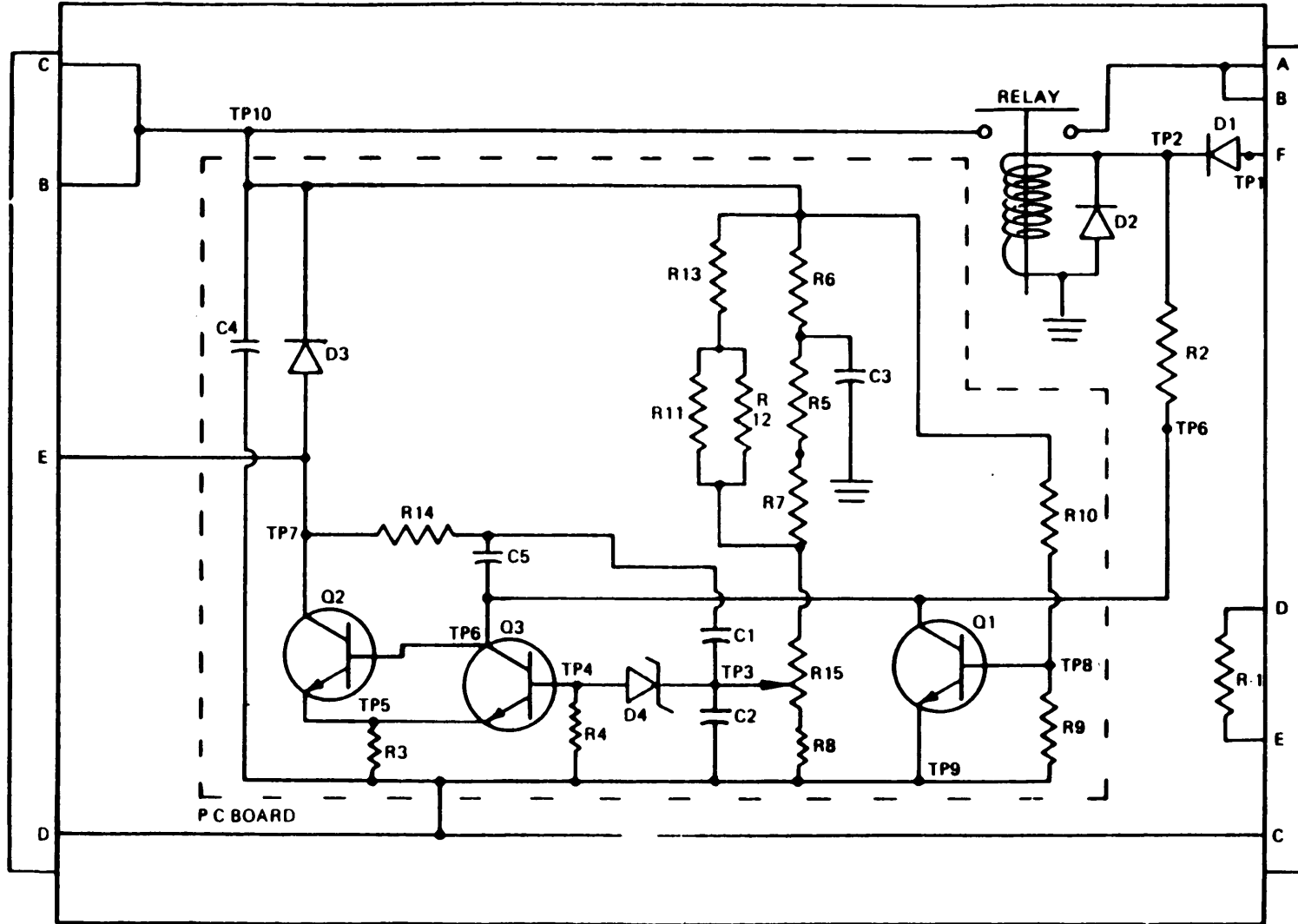

LEECE-NEVILLE REG.
5027-RC

TA178516

Figure 3-11. Schematic diagram—model 5027RC.

Table 3-3. Resistance Checks (Power Off) - Model 5027RC

NOTE

ADJUST R15 FULLY CLOCKWISE BEFORE MAKING THESE CHECKS

| Red for TS352 Negative | Black for TS352 Positive | Resistance (OHMS) | Resistance Scale (TS352 Meter) | Component | NSN |
|--|--|--|-----------------------------------|---|--------------------------------------|
| TP1 TP2 | TP2 TP1 | OVER 500 15-30 | R x 1 | DIODE D1 1N1342A | 5961-00-054-9138 |
| TP2 | TP9 | 15-25 | R x 1 | RELAY 11602713 DIODE D2 1N4820 | 2920-00-735-9542 5961-00-624-4929 |
| TP9 | TP2 | 30-50 | | | |
| TP7 TP10 | TP10 TP7 | 15-30 300-700 | R x 1 | DIODE D3 1N3022B | 5961-00-038-0809 |
| TP3 TP4 | TP4 TP3 | 15-30 200-500 | R x 1 | DIODE D3 1N3022B | 5961-00-038-0809 |
| TP5 TP4 TP4 TP6 TP6 TP5 | TP4 TP5 TP6 TP4 TP5 TP6 | 15-25 100-200 150-500 15-25 10-25 10-25 | R x 1 | TRANSISTOR Q3 26316033-20 | 5961-00-133-0396 |
| TP6 TP8 TP8 TP9 TP9 TP6 | TP8 TP6 TP9 TP8 TP6 TP9 | 10-25 20-30 4 4 10-25 10-25 | R x 1 | TRANSISTOR Q1 2N3447 | 5961-00-899-9899 |

Table 3-4. Voltage Checks (Power On)—Model 5027RC

NOTE

ADJUST R15 FULLY CLOCKWISE BEFORE MAKING THESE CHECKS

| Red for TS352 Positive | Black for TS352 Negative | Voltage* (Volts) | Regulator Applied Voltage | Component | NSN |
|---|-----------------------------|--|------------------------------|---------------------|------------------|
| TP1 TP2 TP3 TP4 | J1-PIN D " " " | 20.0 19.5 12.0 BELOW .25 | 20.0 " " " | DIODE D4 1N3022B | 5961-01-038-0809 |
| TP5 TP6 TP7 TP8 TP9 TP10 | " " " " " " | 0.0 .80 .10 .20 0.0 20.0 | " " " " " " | | |
| TP1 TP2 TP3 TP4 | J1-PIN D " " " | 30.0 29.5 13.0 .75 | 30.0 " " " | DIODE D4 1N3022B | 5961-01-038-0809 |
| TP5 TP6 TP7 TP8 TP9 TP10 | " " " " " " | 0.0 .15 30.0 .25 0.0 30.0 | " " " " " " | | |

*Values may vary ± 5%

Section V. LEECE-NEVILLE MODEL R0015027RD

3-10. General. Figure 3-12 is a plan view of the regulator with the cover removed, showing the heat sink and the circuit board. The components are indicated by their reference designations, and on the circuit board the terminals are associated wire colors are also indicated. Figure 3-13 is a plan view of the regulator with the cover, heat sink and circuit board removed, showing the relay and remaining components. The components are indicated by their reference designations, and test points 1 through 5 are shown. Figure 3-14 is a plan view of the regulator with the cover removed, showing test points 6 through 18. There are 18 total test points. Figure 3-15 is an electrical schematic diagram of the regulator circuit.

3-11. Checkout and Repair.

a. Relay (see Figs. 3-13 and 3-14) (power disconnected).

(1) Place positive probe of ohmmeter on pin F of connector J2 and negative probe on TP1 (white/yellow wire). Meter should read low ohms (hundreds).

(2) Reverse probes. Meter should read high ohms (thousands).

(3) If other readings are obtained, see detailed circuit check below.

(4) Place ohmmeter positive probe on TP2 and negative probe on TP1. Meter should read approximately 50 ohms.

(5) Reverse probes. Meter should read low ohms (more than 10 and less than 100).

(6) If other readings are obtained, disconnect the WHT/YLW wire on TP1 and repeat (4) and (5) looking for a meter reading of 40 to 60 ohms in each case. If other readings are obtained replace the relay, NSN 5945-00-409-3883. Replace the WHT/YLW wire on TP1.

(7) Place ohmmeter probes on TP3 and TP4. Meter should read infinity (open circuit). If other readings are obtained replace the relay, NSN 5945-00-409-3883.

(8) Place positive ohmmeter probe on TP17 and negative probe on TP8. The reading should be greater than 10 ohms and less than 100 ohms; if not replace Q1, NSN 5961-00-730-3284.

(9) Place positive ohmmeter probe on TP12 and negative probe on TP13. Rotate the potentiometer. Full counterclockwise should be 0 ohms, gradually increasing to 100 ohms at full clockwise. If not, replace the potentiometer. The potentiometer is a 100 ohm, 2 watt, tab-mounted device.

Failed devices have been successfully replaced with part number 71590-WT-100 by performing some minor mechanical modification.

Globe-Union Inc. FSCM 71590
Centralab Electronics Div.
Hwy. 20 W. P.O. Box 858
Fort Dodge, IA 50501

(10) Place positive ohmmeter probe on TP15 and negative probe on TP16. The reading should be greater than 10 ohms and less than 100 ohms; if not, replace D3.

b. Resistor R10.

(1) Place ohmmeter probes on pins D and E of connector J2. Meter should read approximately 0.4 ohms.

(2) If other readings are obtained, replace resistor.

c. Resistor R9.

(1) Place ohmmeter probes on TP5 and pin C of connector J2. Meter should read 0 ohms plus (resistor is actually rated at 0.05 ohms).

(2) If other readings are obtained, check the wiring from the bottom terminal of the resistor to pin C on connector J2. If the wire continuity is good, replace the resistor.

d. Detailed Circuit Checks. Table 3-5 contains "power off" resistance checks of the circuit (see figs. 3-12, 3-14 and 3-15 for test points).

e. Functional Check. Check the performance of the regulator on the test stand and make final voltage adjustments. Voltage output should read 28 volts. If the regulator does not function properly, perform the following:

(1) Check wires and connections.

(2) Replace cover assembly.

(3) Perform bench test procedures.

NOTE

After final repair, check regulator on the test stand.

If the regulator still does not function correctly it will be necessary, if local skills permit, to test each component. All the parts should be checked with an ohmmeter and the capacitors checked with a capacitance meter. The circuit board traces should be checked with an ohmmeter to ensure that there are no cracked traces. Traces with hairline cracks will show as good at lower temperatures and will tend to show open circuit at higher temperatures. If the board seems good at room temperature, but the regulator still fails, this could be the cause.

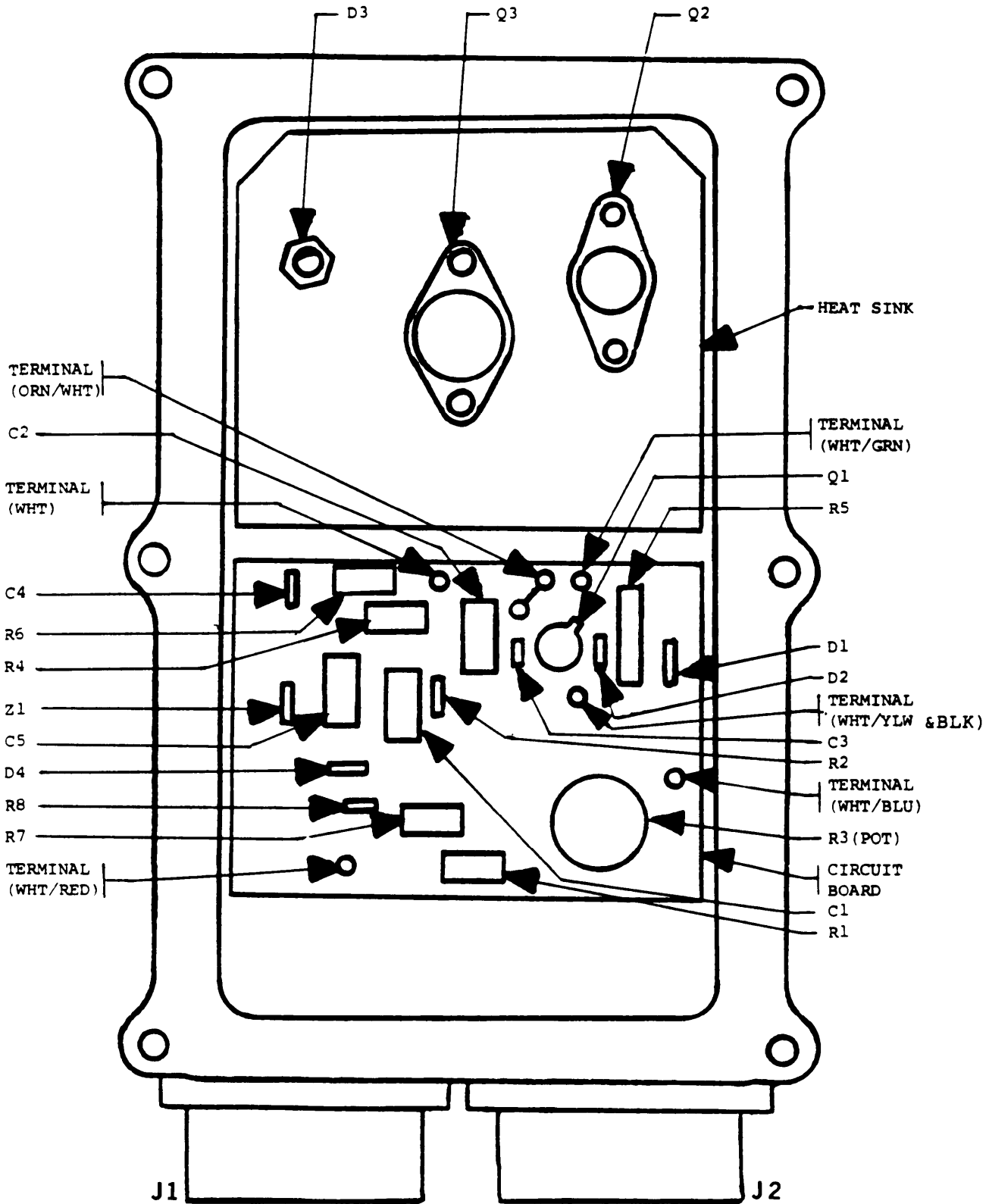

Figure 3-12. Leece-Neville-model 5027RD.

TA178517

Table 3-5. Resistance Checks (Power Off) - Model 5027RD

NOTE**ADJUST R3 FULLY COUNTERCLOCKWISE BEFORE MAKING THESE CHECKS**

| Red for TS352 Negative | Black for TS352 Positive | Resistance (OHMS) | Resistance Scale | Component | NSN |
|---------------------------|-----------------------------|--------------------------|------------------|--------------------------------------|------------------------------------|
| TP10 TP11 | TP11 TP10 | OVER 500 UNDER 100 | R x 1 | DIODE D1 MR 502 | 5961-00-577-0771 |
| TP10 J2-C | J2-C TP10 | APPROX. 50 APPROX. 50 | R x 1 | DIODE D2 1N4004 and RELAY COIL | 5961-00-914-6005 |
| J1-C J1-E | J1-E J1-C | OVER 500 UNDER 100 | R x 1 | DIODE D3 MR1122R | 5961-00-103-1519 |
| TP6 TP7 | TP7 TP6 | OVER 500 UNDER 100 | R x 1 | DIODE D4 1N4004 | 5961-00-914-6005 |
| TP9 TP8 | TP8 TP9 | OVER 500 UNDER 100 | | DIODE Z1 1N746 | (See table 3-6 for substitutes) |

Table 3-6. Substitutes for Diode Z1-Model 5027RD

| P/N | NSN |
|--------|--------------------------------------|
| 1N746A | 5961-00-018-8383 5961-00-847-5246 |

LEGEND TO FIGURE 3-12

| | | | |
|----|---|----|--------------------------------|
| C1 | 22 Micro Farad 35 Volt | R2 | 250 ohm, ½ Watt |
| C2 | 22 Micro Farad 15C Volt | R3 | 100 ohm Potentiometer, 2 Watt |
| C3 | .047 Micro Farad | R4 | 410 ohm, ½ Watt |
| C4 | .047 Micro Farad | R5 | 500 ohm, 3 Watt |
| C5 | 22 Micro Farad 150 Volt | R6 | 5.1 Kohm, ½ Watt |
| D1 | MR502 Diode, 3A 200 Volt NSN 5691-00-577-0771 | R7 | 1.8 Kohm, ½ Watt |
| D2 | 1N4004 Diode NSN 5961-00-914-6005 | R8 | Thermistor |
| D4 | 1N4004 Diode | Z1 | 1N746 Zener Diode 3.3 Volts VZ |
| R1 | 250 ohm, ½ Watt | Q1 | 2N2405 NSN 5961-00-730-3284 |

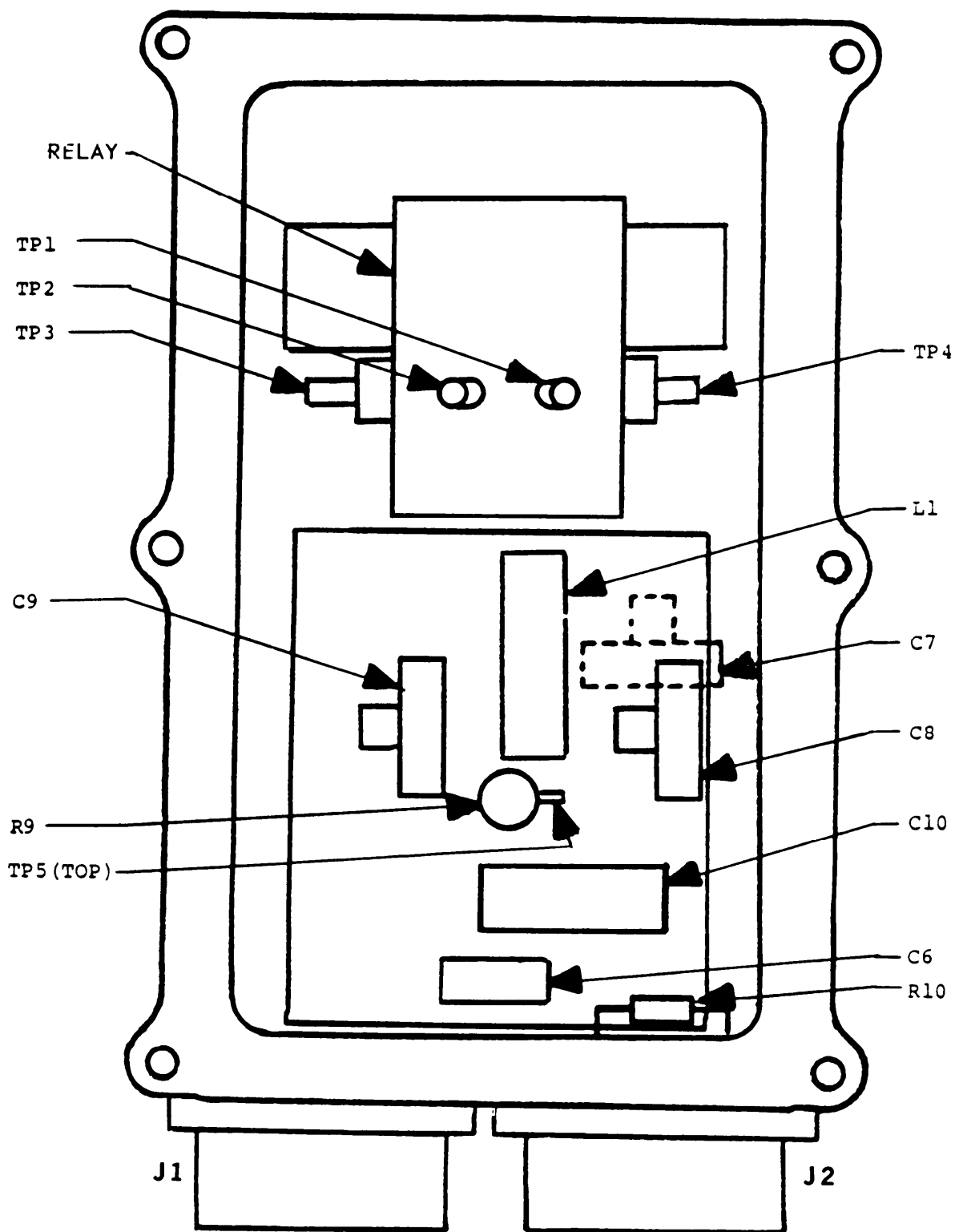

TA178518

C6 .47 Micro Farad 200 Volt
 C7 .47 Micro Farad 150 Volt
 C8 .47 Micro Farad 150 Volt
 C9 .47 Micro Farad 150 Volt

C10 4 Micro Farad 200 Volt
 R9 .05 ohm, 8 Watt
 R10 .4 ohms, 1 Watt

Figure 3-13. Circuit board removed-model 5027RD.

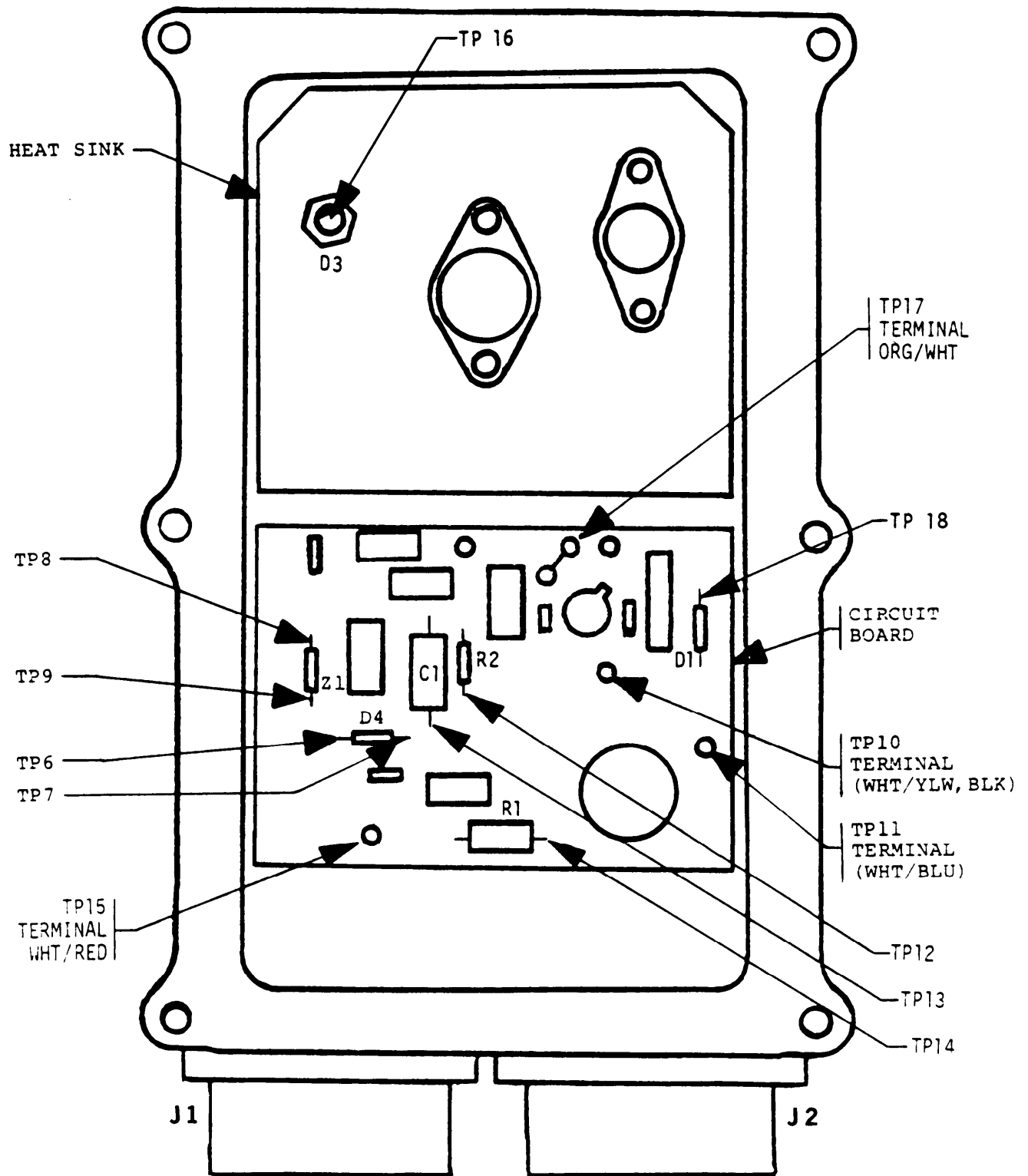
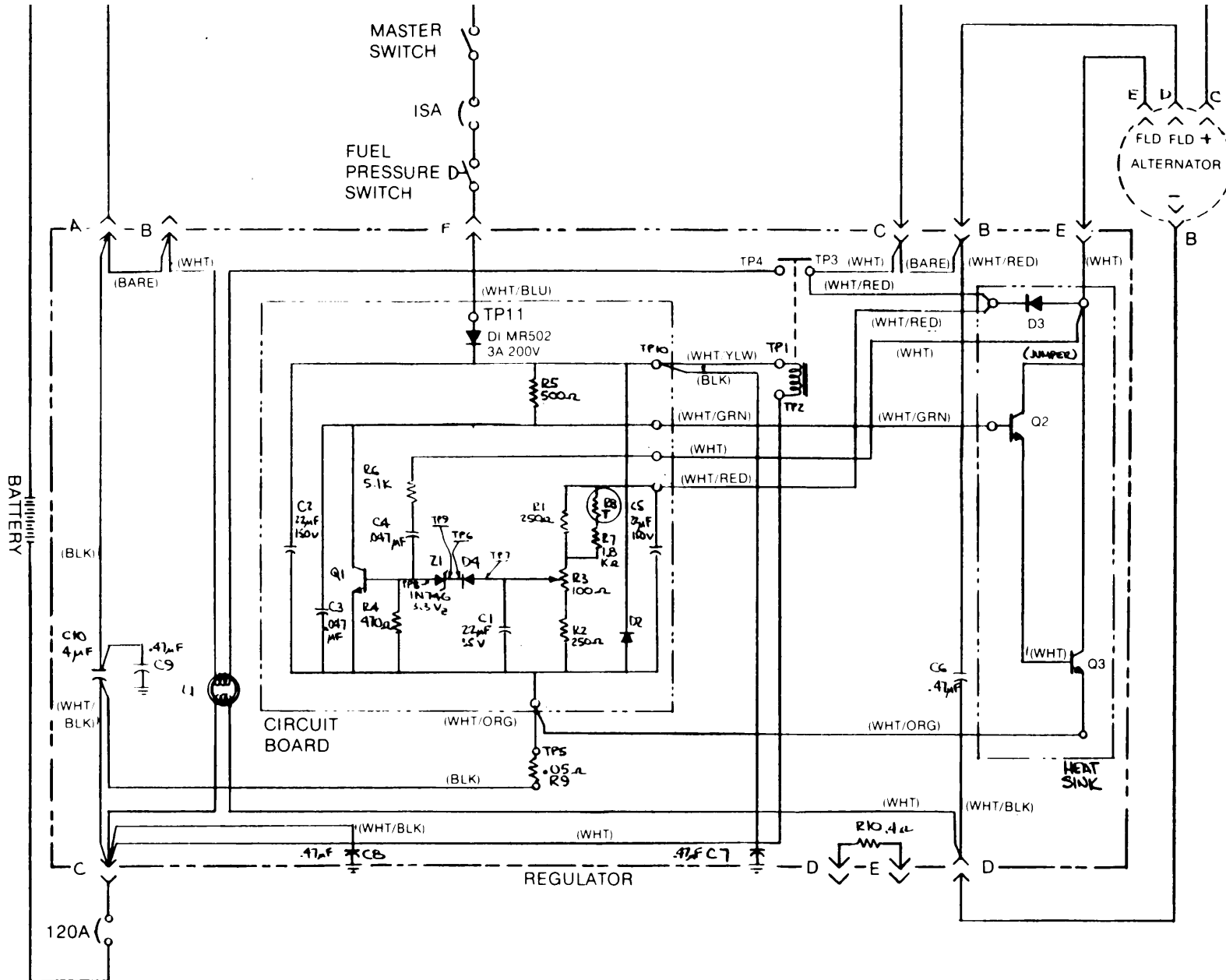

Figure 3-14. Test points-model 5027RD.

TA178519



TA178520

Figure 3-15. Schematic diagram—model 5027RD.

CHAPTER 4

LELAND AIRBORNE MODEL

4-1. Introduction. One model was produced by Leland Airborn Products Division of American Machine and Foundry Co. The manufacturer's name is now:

CODE IDENT 07639 (FSCM)
Leland Electrosystems Inc.
740 E. National Road
P.O. Box 128
Vandalia, OH 45377

TELEPHONE AC 513898-5881

The manufacturer is also now known as AMF Electrosystems Division at the same address. The manufacturer's part number for this model is CSV 2183-1.

4-2. General Inspection.

a. Regulator Box Assembly (external). Check for missing or stripped cover, connector and mount retainer screws and voltage adjustment access plug. Check connectors for signs of arcing, bent or pushed in pins, broken connectors and thread damage. Correct deficiencies by utilization of serviceable components from unrepairables or requisitioning components from the manufacturer. The pin receptacle (J2) is part number 19207-7064429 or MS3102A28-22P per MIL-C-5015. The socket receptacle (J1) is part number 19207-7064706, for which there is no equivalent NSN number.

As assembly is available from Bendix.

CODE IDENT 77820 (FSCM)
Bendix Corp. The Electrical
Components Div.
Sherman Avenue
Sidney, NY 13838

It should be ordered as part number 60-42228-10S, it is possible that extensive damage has been done and the regulator cannot be easily repaired. Components should be performance tested and retained if acceptable. Check for disconnected or burnt wires, missing components and replace/repair as necessary. Carefully remove the transistor mounting plate noting the position of the screws,

washers and rubber insulators. Visually inspect the circuit board for burnt components. Replace the circuit board through cannibalization if burnt components are found. Carefully reinstall the transistor mounting plate.

c. Regulator Verification Check. After performing the regulator appears to be in good condition, check its performance on a test stand.

If the regulator fails this check, proceed to paragraph 4-3.

4-3. Bench Testing.

a. General. Figures 4-1 and 4-2 show the method for testing NPN transistors. Figure 4-3 shows a plan view of the circuit board assembly, the regulator with the cover and circuit board removed, and an electrical schematic diagram of the regulator.

b. Diode and Relay.

(1) Remove six screws and place the circuit board to one side.

(2) Place positive probe of ohmmeter to pin F of connector J2, (see fig. 4-3).

(3) Place negative probe to TP1. Meter should indicate low resistance.

(4) Reverse probes. Meter should indicate high resistance.

(5) If other readings are obtained, replace diode CR6, (see fig. 4-3).

(6) Move negative probe to TP2. Meter should read approximately 250 ohms.

(7) If another reading is obtained, replace the relay, (see fig. 4-3).

c. Field Discharge Diode.

(1) Place positive probe of ohmmeter to pin E of connector J1 (see fig. 4-3).

(2) Place negative probe to pin B of J1. Meter should indicate low resistance.

(3) Reverse the probes. Meter should indicate high resistance.

(4) If other readings are obtained, replace diode CR7.

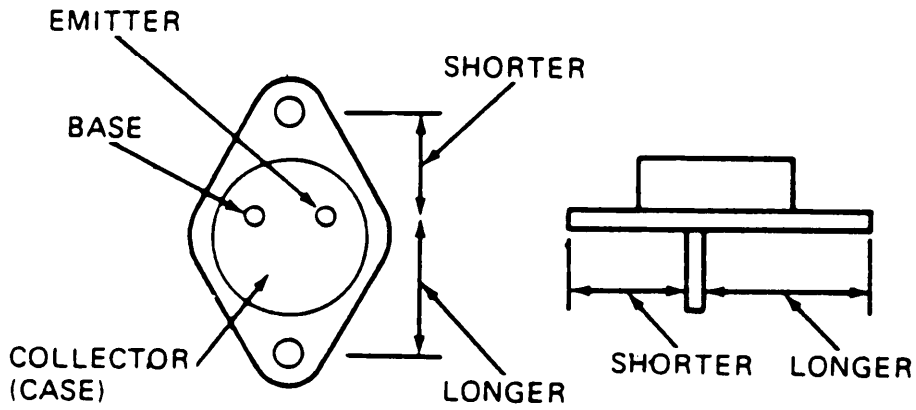

TA178521

Figure 4-1. NPN transistor (Leland Airborne model).

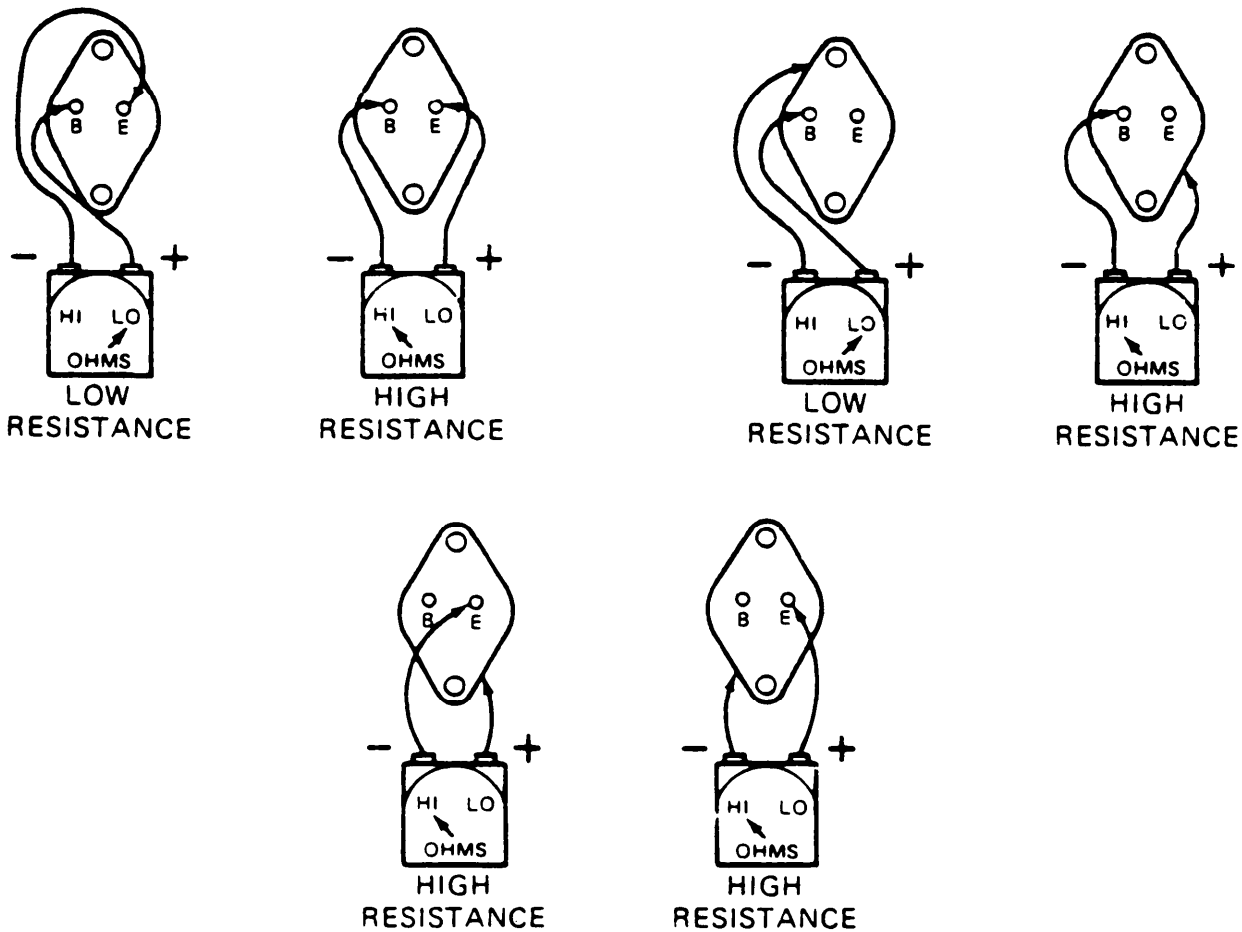

TA 178522

Figure 4-2. Transistor resistance checks (Leland Airborne model).

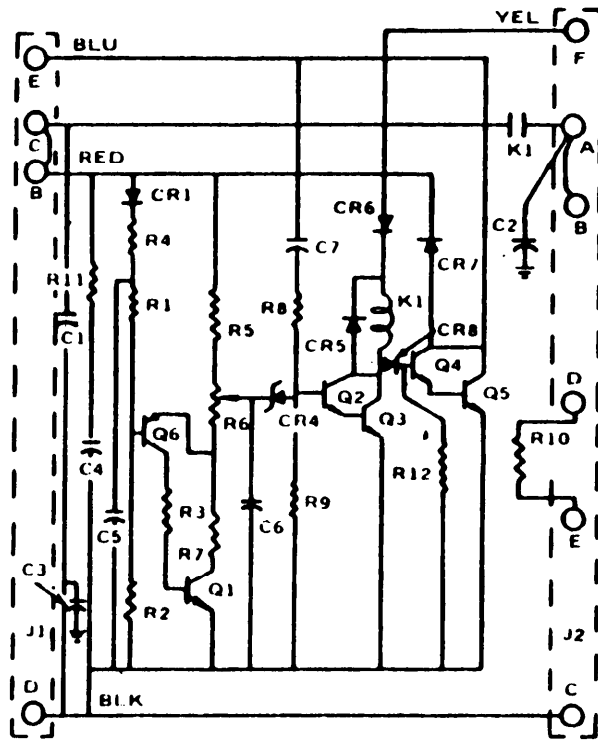

LEGEND

| | |
|--------------|-----------------------|
| R1 | 150K Ω , 1/2W |
| R2 | 59K Ω , 1/2W |
| R3 | 100K Ω , 1/2W |
| R4 | 220 Ω , 1/2W |
| R5 | 4.75K Ω , 1/2W |
| R6 | Var. 1K Ω , 2W |
| R7 | 3.32K Ω , 1/2W |
| R8 | 130K Ω , 1/2W |
| R9 | 10K Ω , 1/2W |
| R10 | .39 Ω , 2W |
| R11 | 1.2 Ω , 2W |
| R12 | 470 Ω , 1/2W |
| C1, C2, C3 | .47 μ f, 200V |
| C4 | 2 μ f, 200V |
| C5 | 1.5 μ f, 200V |
| C6 | .22 μ f, 100V |
| C7 | .022 μ f, 200V |
| CR1 | 75ma, 100V |
| CR4 | (Z) .25W, 10V |
| CR5, CR6 & 8 | 150ma, 200V |
| CR7 | 5A, 200V |
| Q1, Q2, Q3 | 2N3415 |
| Q4 | 2N3441 |
| Q5 | 2N3772 (100V) |
| Q6 | 2N5142 |
| K1 | Relay P&B MB-1285 |
| J1 | Conn. 7064706 |
| J2 | Conn. 7064429 |

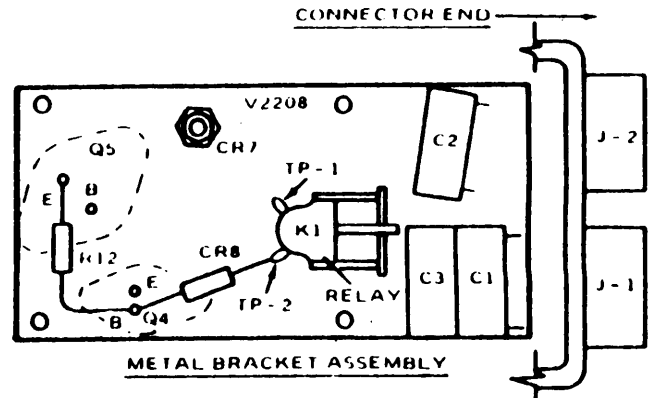
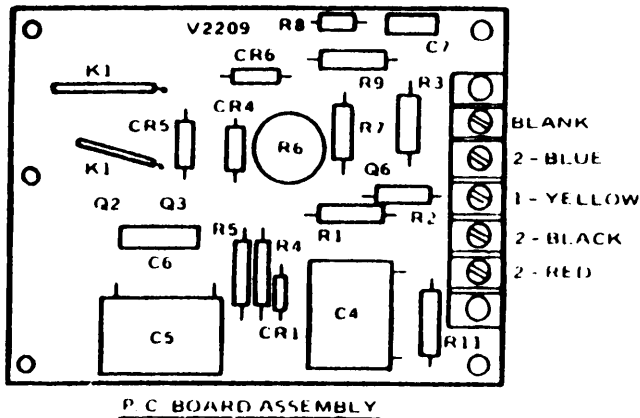

TA 178523

Figure 4-3. Schematic diagram, circuit board, and bracket assy (Leland Airborne model).

d. *Transistors.*

NOTE

Transistors Q4 and Q5 can be checked fairly accurately without removing them from the circuit.

- (1) Check transistors Q4 and Q5, (see fig. 4-3), inaccordance with figures 4-1 and 4-2.

NOTE

Due to the connection of Q4 in the circuit, omit the emitter to collector check in figure 4-2.

- (2) If other readings are obtained, replace transistors Q4 and Q5.

e. *Circuit Board.* If no faulty components were detected after performing tests a, b, and c, replace the circuit board.

f. *Functional Check.* Check the performance of the regulator on the test stand and make final voltage adjustments. Voltage output should read 28 volts. If the regulator does not function properly, perform the following:

- (1) Check wires and connections.
- (2) Replace circuit board.
- (3) Perform bench test procedures.

NOTE

After final repair, check regulator on the test stand.

If the regulator still does not function correctly it will be necessary, if local skills permit, to test each component. All the parts should be checked with an ohmmeter and the capacitors checked with a capacitance meter. The circuit board traces should be checked with an ohmmeter to ensure that there are no cracked traces. Traces with hair-line cracks will show good at lower temperatures and will tend to show open circuit at higher temperatures. If the board seems good at room temperature, but the regulator still fails, this could be the cause.

Table 4-1. Replacement Parts List-
Leland Airborne Model

| REPLACEMENT PARTS LIST | | |
|-------------------------------|----------------------------------|--|
| Ref | P/N | NSN |
| CR1, CR5, CR6, CR8 | 1N4004 | 5961-00-914-6005 |
| CR4 | 1N4697 | 5961-00-247-3046 |
| CR7 | 1N1614R 1N1616R | 5961-00-069-6767 or 5961-00-926-0208 |
| Q1, Q2, Q3 | 2N3415 | 5961-00-931-8231 |
| Q4 | 2N3441 | 5961-00-054-4141 |
| Q5 | 2N3772 | 5961-00-438-2156 5961-00-854-6759 or 5961-00-864-7527 |
| Q6 | 2N5142 | 5961-00-483-4396 |

CHAPTER 5

100 AMP REGULATOR CHECKER

5-1. Purpose. This checker is intended to provide quick bench tests to determine the general condition of the regulator. The checker is not intended to replace the authorized test stands which are necessary to determine the accurate operating condition of the regulator.

5-2. Construction. The regulator checker can be locally fabricated using salvaged components. The mini-ammeter is an optional feature and most any meter can be used, provided it is shunted to give midscale reading.

5-3. Power Supply. The regulator checker is used in conjunction with a variable external power supply having the following characteristics:

- a. Voltage range 0-32 volts DC minimum.
- b. Current range must be at least 2 AMPS.
- c. The output power must be well filtered.

NOTE

The 500 AMP test stands, external power supply is adequate if additional filtering is added.

5-4. Operation.

- a. Connect the checker to the regulator to be tested.
- b. Connect power supply to the checker.

CAUTION

Be sure proper polarity is maintained.

- c. Advance the power supply voltage control and note the voltage when the regulator relay is closed and the main circuit light comes on. This is the relay closing voltage.

- d. Advance the voltage to 20 volts. The field indicator light should come on if the regulator switching transistors are functioning.

- e. Advance the voltage until the field light turns off (maximum of 32 volts). The light should shut off if the regulating and switching transistors are functioning correctly.

- f. Adjust the power supply voltage to 28 volts, adjust the regulator voltage adjusting rheostat until the field indicator light turns off.

- g. If the regulator fails these checks, perform bench tests and repairs.

- h. If the regulator passes these checks, perform final tests on the authorized test stand.

5-5. Mini-Ammeter Operation. If the regulator checker is equipped with the optional meter, the following additional data can be obtained.

- a. Note the average regulator current draw from several regulators which are known to be in good operating condition.

- b. While performing the above, check if the meter reading is higher than normal, check for shorted components and circuit. If the reading is lower than normal, check for open circuits and components.

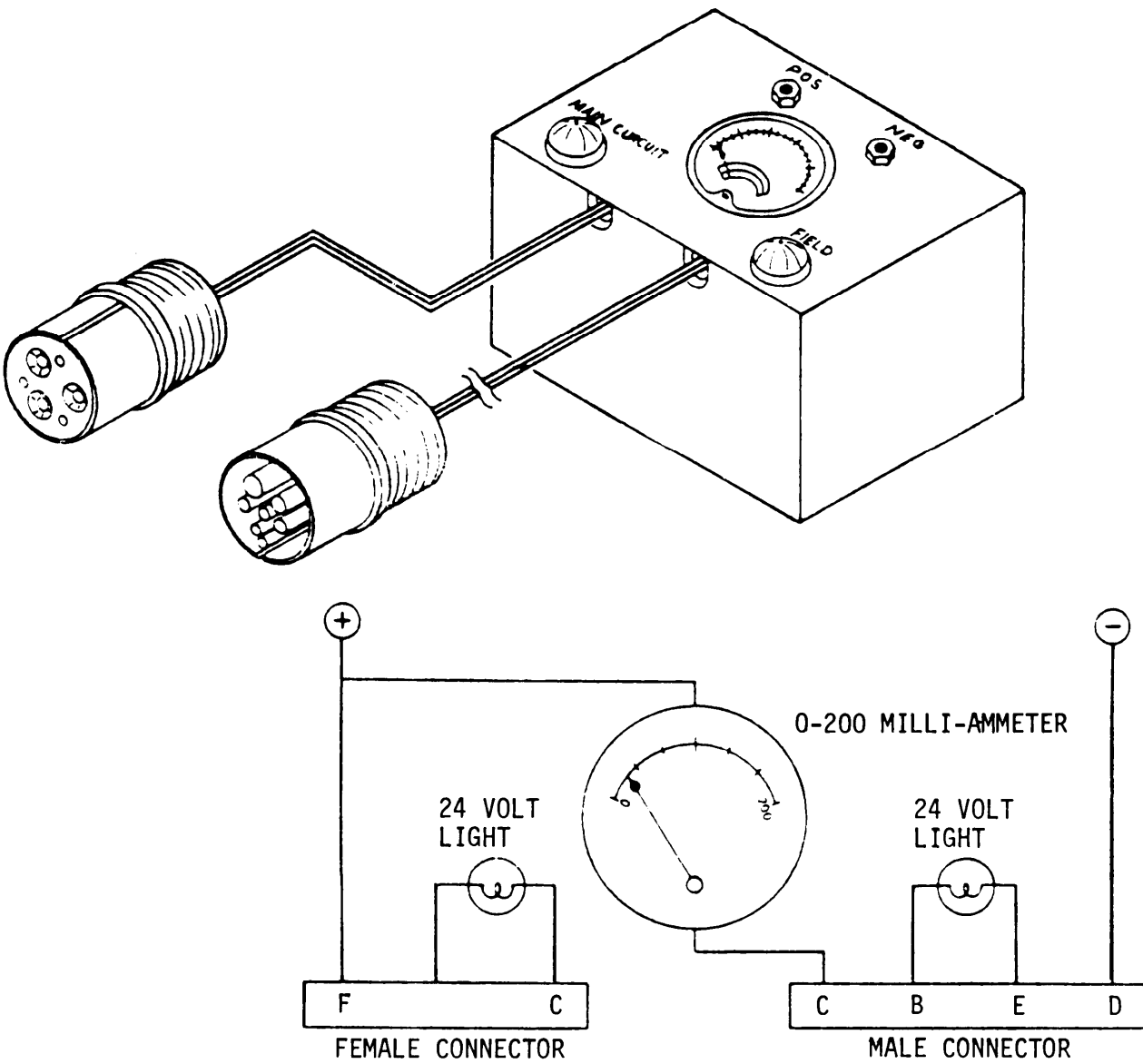

Figure 5-1. 100 AMP solid state regulator checker.

APPENDIX A
CONSOLIDATED NATIONAL STOCK NUMBERS (NSN)
AND FEDERAL SUPPLY CODES FOR MANUFACTURERS (FSCM)

National numbers listed in this appendix are in National Item Identification Number Sequence (NIIN).

| NSN | P/N | FSCM | NSN | P/N | FSCM |
|------------------|--------------|-------|------------------|--------------|-------|
| 5961-00-018-8383 | 1N746A | 15818 | 5961-00-730-3284 | 2N2405 | 01281 |
| 5961-00-054-4141 | 2N3441 | 81349 | 2920-00-735-9542 | 11602713 | 19207 |
| 5961-00-054-9138 | 1N1342A | 05277 | 5916-00-758-5816 | JANTX 2N3371 | 81349 |
| 5961-00-068-2001 | 1N756A | 01281 | 5961-00-760-1302 | JANTX 2N3772 | 81349 |
| 5961-00-069-6767 | 1N1614R | 08225 | 5961-00-761-4631 | 1N5402 | 05277 |
| 5961-00-078-0628 | 1N938A | 04713 | 5961-00-811-3752 | 1N936 | 85005 |
| 5961-00-103-1519 | MR1122 | 04713 | 5961-00-833-9050 | 1N2482 | 12045 |
| 5961-00-105-5734 | JANTX 1N756A | 81349 | 5961-00-845-6458 | 1N756A | 81349 |
| 5961-00-133-0396 | 26316033-20 | 99167 | 5961-00-847-5246 | 1N746A | 25228 |
| 5961-00-215-5999 | 2N5039 | 02735 | 5961-00-852-5174 | JAN 1N939B | 81349 |
| 5961-00-223-2230 | MR1122R | 04713 | 5961-00-854-6759 | 2N3772 | 21929 |
| 5961-00-226-5134 | JAN 1N937B | 81349 | 5961-00-858-8960 | JAN 2N5038 | 81349 |
| 5961-00-247-3046 | 1N4697 | 01281 | 5961-00-864-7527 | 2N3772 | 54590 |
| 5961-00-255-9986 | 2N6258 | 02735 | 8040-00-877-9872 | MIL-A-64106 | 91349 |
| 5961-00-262-0729 | 2N5039 | 81349 | 5961-00-879-7145 | 1N936B | 12954 |
| 5945-00-270-1209 | 71136 | 35510 | 5961-00-880-4783 | 1N4002 | 04713 |
| 5961-00-327-8280 | 2N3773 | 54590 | 6850-00-880-7616 | MIL-S-8660 | 81349 |
| 5961-00-359-5752 | JANTX 2N5038 | 81349 | 5961-00-892-0889 | JAN 1N938B | 81349 |
| 5961-00-400-1992 | 1N959A | 01281 | 5961-00-892-3195 | 1N936A | 04713 |
| 5061-00-403-2566 | JAN 2N3772 | 81349 | 5961-00-899-9899 | 2N3447 | 04713 |
| 5945-00-409-3883 | EK212 | 31211 | 5961-00-912-9008 | 2N3638A | 12040 |
| 5961-00-431-7863 | JAN 2N3771 | 81349 | 5961-00-914-6005 | 1N4004 | 04713 |
| 5961-00-438-2156 | 2N3772 | 02735 | 5961-99-926-0208 | 1N1616R | 81349 |
| 5961-00-450-0922 | 1N4721 | 04713 | 5961-00-929-4975 | 1N4721 | 14028 |
| 5961-00-462-3077 | 8106497-1 | 31550 | 5961-00-929-5014 | 2N3773 | 04713 |
| 5961-00-481-4205 | 2N5671 | 01281 | 5961-00-931-8231 | 2N3415 | 08257 |
| 5961-00-483-4396 | 2N5142 | 27014 | 5961-00-935-6479 | 2N5038 | 13715 |
| 5961-00-484-5035 | JANTX 1N937B | 81349 | 5961-00-938-7649 | 1N4141 | 06288 |
| 5961-00-484-5036 | JANTX 1N938B | 81349 | 5961-00-951-8757 | 2N2222A | 81349 |
| 5961-00-523-9171 | 2N5679 | 94990 | 5961-01-003-0584 | 2N6579 | 04713 |
| 5961-00-577-0771 | MR502 | 04713 | 5961-01-017-0990 | JANTX 2N5672 | 81349 |
| 5905-00-581-1405 | 669-0150 | 02032 | 5961-01-019-6400 | JAN 2N5671 | 81349 |
| 5961-00-620-9770 | 1N938 | 04713 | 5961-01-033-0822 | JANTX 2N5039 | 81349 |
| 5961-00-624-4929 | 1N4820 | 01295 | 5961-01-038-0809 | 1N3022B | 04713 |

By Order of the Secretary of the Army:

Official:

E. C. MEYER
General, United States Army
Chief of Staff

ROBERT M. JOYCE
Brigadier General, United States Army
The Adjutant General

Distribution:

To be distributed in accordance with DA Form 12-38, TB requirements
for 1/4 Ton Truck Utility, M151A2.

RECOMMENDED CHANGES TO EQUIPMENT TECHNICAL PUBLICATIONS



THEN... JOT DOWN THE DOPE ABOUT IT ON THIS FORM, CAREFULLY TEAR IT OUT, FOLD IT AND DROP IT IN THE MAIL!

SOMETHING WRONG WITH THIS PUBLICATION?

FROM: (PRINT YOUR UNIT'S COMPLETE ADDRESS)

Your mailing address

DATE SENT

Date you filled out form

PUBLICATION NUMBER

TB 9-XXXX-XXX-XX

PUBLICATION DATE

Date of TB

PUBLICATION TITLE

Title of TB

BE EXACT. PIN-POINT WHERE IT IS

| PAGE NO. | PARA-GRAPH | FIGURE NO. | TABLE NO. |
|----------|------------|------------|-----------|
| 20 | | 2-8 | |

IN THIS SPACE TELL WHAT IS WRONG AND WHAT SHOULD BE DONE ABOUT IT:

Illustration should be corrected Test Point 22 is missing.

SAMPLE

PRINTED NAME, GRADE OR TITLE, AND TELEPHONE NUMBER

JOHN DOE S/P 3 XXX-XXXX

SIGN HERE:

John Doe

DA FORM 2028-2
1 JUL 79

PREVIOUS EDITIONS ARE OBSOLETE.

P.S.—IF YOUR OUTFIT WANTS TO KNOW ABOUT YOUR RECOMMENDATION MAKE A CARBON COPY OF THIS AND GIVE IT TO YOUR HEADQUARTERS.

TEAR ALONG PERFORATED LINE

RECOMMENDED CHANGES TO EQUIPMENT TECHNICAL PUBLICATIONS

SOMETHING WRONG WITH THIS PUBLICATION?



THEN... JOT DOWN THE DOPE ABOUT IT ON THIS FORM. CAREFULLY TEAR IT OUT. FOLD IT AND DROP IT IN THE MAIL!

FROM: (PRINT YOUR UNIT'S COMPLETE ADDRESS)

DATE SENT

PUBLICATION NUMBER

TB 9-2920-225-34-1

PUBLICATION DATE

10 Nov 81

PUBLICATION TITLE 100 Amp Regulator
(Solid State) Checkout and Repair
Procedures

BE EXACT. PIN-POINT WHERE IT IS

PAGE NO.

PARA-GRAPH

FIGURE NO.

TABLE NO.

IN THIS SPACE TELL WHAT IS WRONG AND WHAT SHOULD BE DONE ABOUT IT:

TEAR ALONG PERFORATED LINE

PRINTED NAME, GRADE OR TITLE, AND TELEPHONE NUMBER

SIGN HERE.

DA FORM 2028-2
1 JUL 79

PREVIOUS EDITIONS ARE OBSOLETE.

P.S.—IF YOUR OUTFIT WANTS TO KNOW ABOUT YOUR RECOMMENDATION MAKE A CARBON COPY OF THIS AND GIVE IT TO YOUR HEADQUARTERS.

FILL IN YOUR
UNIT'S ADDRESS

FOLD BACK

DEPARTMENT OF THE ARMY

POSTAGE AND FEES PAID
DEPARTMENT OF THE ARMY
DOD 314



OFFICIAL BUSINESS
PENALTY FOR PRIVATE USE \$300

Commander
US Army Tank-Automotive Command
ATTN: DRSTA-MB
Warren, MI 48090

TEAR ALONG PERFORATED LINE

THE METRIC SYSTEM AND EQUIVALENTS

WEIGHT MEASURE

1 Centimeter = 10 Millimeters = 0.01 Meters = 0.3937 Inches
 1 Meter = 100 Centimeters = 1000 Millimeters = 39.37 Inches
 1 Kilometer = 1000 Meters = 0.621 Miles

WEIGHTS

1 Gram = 0.001 Kilograms = 1000 Milligrams = 0.035 Ounces
 1 Kilogram = 1000 Grams = 2.2 lb.
 1 Metric Ton = 1000 Kilograms = 1 Megagram = 1.1 Short Tons

LIQUID MEASURE

1 Milliliter = 0.001 Liters = 0.0338 Fluid Ounces
 1 Liter = 1000 Milliliters = 33.82 Fluid Ounces

SQUARE MEASURE

1 Sq. Centimeter = 100 Sq. Millimeters = 0.155 Sq. Inches
 1 Sq. Meter = 10,000 Sq. Centimeters = 10.76 Sq. Feet
 1 Sq. Kilometer = 1,000,000 Sq. Meters = 0.386 Sq. Miles

CUBIC MEASURE

1 Cu. Centimeter = 1000 Cu. Millimeters = 0.06 Cu. Inches
 1 Cu. Meter = 1,000,000 Cu. Centimeters = 35.31 Cu. Feet

TEMPERATURE

$5/9(^{\circ}\text{F} - 32) = ^{\circ}\text{C}$
 212° Fahrenheit is equivalent to 100° Celsius
 90° Fahrenheit is equivalent to 32.2° Celsius
 32° Fahrenheit is equivalent to 0° Celsius
 $9/5^{\circ}\text{C} + 32 = ^{\circ}\text{F}$

APPROXIMATE CONVERSION FACTORS

| TO CHANGE | TO | MULTIPLY BY |
|------------------------|----------------------|-------------|
| Inches | Centimeters | 2.540 |
| Feet | Meters | 0.305 |
| Yards | Meters | 0.914 |
| Miles | Kilometers | 1.609 |
| Square Inches | Square Centimeters | 6.451 |
| Square Feet | Square Meters | 0.093 |
| Square Yards | Square Meters | 0.836 |
| Square Miles | Square Kilometers | 2.590 |
| Acres | Square Hectometers | 0.405 |
| Cubic Feet | Cubic Meters | 0.028 |
| Cubic Yards | Cubic Meters | 0.765 |
| Fluid Ounces | Milliliters | 29.573 |
| its | Liters | 0.473 |
| arts | Liters | 0.946 |
| allons | Liters | 3.785 |
| Ounces | Grams | 28.349 |
| Pounds | Kilograms | 0.454 |
| Short Tons | Metric Tons | 0.907 |
| Pound-Feet | Newton-Meters | 1.356 |
| Pounds per Square Inch | Kilopascals | 6.895 |
| Miles per Gallon | Kilometers per Liter | 0.425 |
| Miles per Hour | Kilometers per Hour | 1.609 |

| TO CHANGE | TO | MULTIPLY BY |
|--------------------|------------------------|-------------|
| Centimeters | Inches | 0.394 |
| Meters | Feet | 3.280 |
| Meters | Yards | 1.094 |
| Kilometers | Miles | 0.621 |
| Square Centimeters | Square Inches | 0.155 |
| Square Meters | Square Feet | 10.764 |
| Square Meters | Square Yards | 1.196 |
| Square Kilometers | Square Miles | 0.386 |
| Square Hectometers | Acres | 2.471 |
| Cubic Meters | Cubic Feet | 35.315 |
| Cubic Meters | Cubic Yards | 1.308 |
| Milliliters | Fluid Ounces | 0.034 |
| Liters | Pints | 2.113 |
| Liters | Quarts | 1.057 |
| ers | Gallons | 0.264 |
| ms | Ounces | 0.035 |
| ograms | Pounds | 2.205 |
| Metric Tons | Short Tons | 1.102 |
| Newton-Meters | Pounds-Feet | 0.738 |
| Kilopascals | Pounds per Square Inch | 0.145 |
| ometers per Liter | Miles per Gallon | 2.354 |
| ometers per Hour | Miles per Hour | 0.621 |



PIN: 049797-000